

THE INTRODUCTION TO NIGER OF NUBIAN DOMES AND VAULTS

(CONSTRUCTED IN SUN-DRIED EARTH BRICKS)

June 1991



Contents

	page
Preface	1
Introduction	3
1. Physical and socio-economic context	
1.1 Geography and climate	4
1.2 Socio-economic context	6
2. The problem of the use of wood in building	
2.1 From the point of view of agencies	7
2.2 From the point of view of the local population	7
2.3 From the point of view of the state	9
3. Woodless construction: sun-dried earth vaults and domes	
3.1 Background and reason for this choice	10
3.2 The objective of this transfer of technology	13
4. How were the techniques introduced?	
4.1 "On-the-job" training	13
4.2 Demonstration buildings	14
4.3 Builders' training programmes	14
4.4 Technical support tools	16
5. Achievements to date	
5.1 Buildings constructed	16
5.2 Trained builders	16
5.3 Organizations promoting and spreading the techniques	18
5.4 Clients	18
5.5 Spontaneous construction	22
5.6 The quality of achievements so far	26
5.7 The evolution of forms	28
6. Climatic performance	31

7. Costs	
7.1 Direct costs	32
7.2 Indirect costs	33
8. An assessment of the demand for vaults and domes	
8.1 Overview	34
8.2 Obstacles to the further spreading of the techniques	34
8.3. Public sector demand	34
8.4 Popular demand	34
8.5 Organizational and private demand	35
8.6 Perceived problems	35
9. Towards the future	36
10. Conclusions	37

Three "profiles"

Mallam Abdou: a deeply held conviction	17
Moussa Amgar: an enquiring mind	24
Mouloul Amoumoun: how to satisfy a growing demand?	30

Appendices

Appendix 1: Appropriate "architectural" plans and worksheets
Appendix 2: List of buildings built in Niger and Mali using the Nubian system of vault and dome roofing
Appendix 3: Comparative costs of 3 building types
Appendix 4: Summary of interest in Nubian vault and dome technology
Appendix 5: 3 basic housing structures; plans and sections

Preface

This document concerns the introduction to Niger, West Africa, of a building system unknown in the area before 1980, that is Nubian vault and dome roof building techniques, using sun-dried earth bricks. The techniques addresses the increasing scarcity of organic materials traditionally used in the roofs of buildings and has to a significant extent been adopted by the local population, as a recent survey has shown (1). The original training programme introducing the techniques in 1980 was financed by ISAID (2). In recent years, however, it is principally thanks to the efforts of IUCN/WWF (3) that the techniques have taken root in the local vernacular architecture and IUCN are currently financing a programme to ensure that a local institutional capacity for training and disseminating information about the techniques can be run by Nigerian staff in the future.

The original training programme was run by Development Workshop. A large proportion of the subsequent construction of a wide range of buildings, all of them providing for "on-the-job" training of local masons, as well as some dedicated training programmes, have been carried out, on behalf of ISAID and IUCN/WWF, by a Development Workshop Associate (4). Development Workshop has provided specific technical inputs to address particular problems related to the technology (5) and has also been responsible for producing a manual for local use and technical dossiers for other interested professionals (6). Development Workshop is currently working on behalf of IUCN on the setting up of a local institutional capacity to train local masons and disseminate information on the techniques.

- 1 *Survey undertaken May/June 1990 by Development Workshop on behalf of IUCN (International Union for the Conservation of Nature). See map on following page.*
- 2 *Training programme run in Chikal (see following page) by Allan Cain, Co-Director, Development Workshop, on behalf of ISAID (Institute for the Study and Application of Integrated Development) as part of their "Projet Tapis Vert" (PTV), run in partnership with the Government of Niger.*
- 3 *In partnership with the Government of Niger, "Projet Conservation et Gestion des Ressources Naturelles dans l'Air et le Ténéré" (PAT) - Project for the Conservation and Management of the Natural Resources of the Air and Ténéré - principally centred in and around Iférouane (see following page) where the IUCN/WWF (World Wildlife Fund) project headquarters are located.*
- 4 *Peter Tunley, Development Workshop Associate, responsible for the construction elements of PTV from 1980 to 1984, and of PAT from 1985 to 1990.*
- 5 *Alexandre Douline, Development Workshop, 7-month secondment to PAT in 1987/88; John Norton, Co-Director, Development Workshop, 1-month mission in 1989; Christophe Magnée, Development Workshop, 6-month secondment to PAT in 1989/90. All funded by IUCN/WWF.*
- 6 *Manual produced in 1990 by John Norton and Peter Tunley; 5 technical reports produced in 1989/90 by Alexandre Douline and Peter Tunley. Funded by IUCN.*

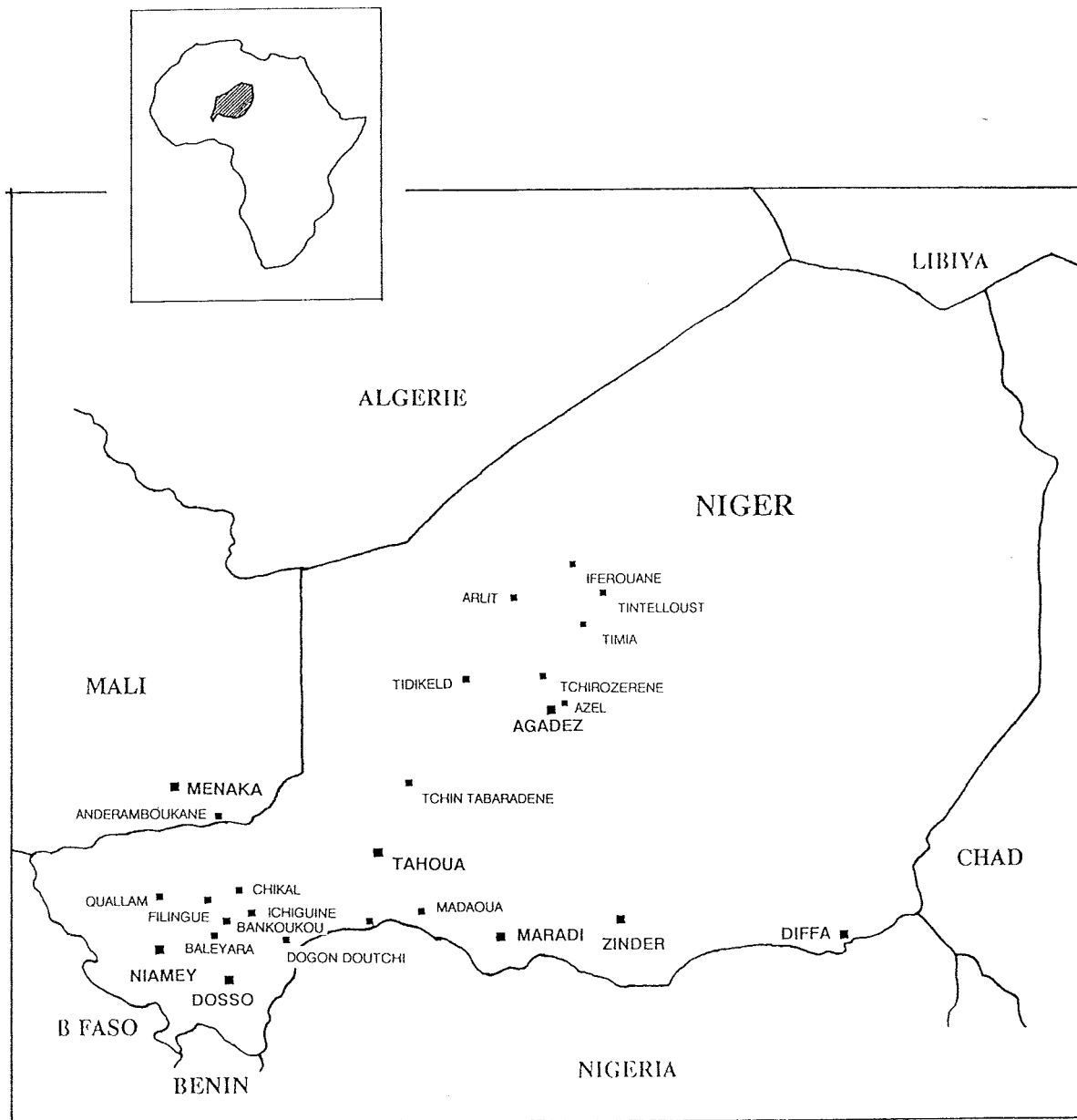

Map showing the location of the principal towns and villages named in this document and visited in the course of a survey by Development Workshop on behalf of IUCN in May/June 1990.

Introduction

In 1980 an integrated rural development project (7) in Niger became aware of problems in obtaining organic materials, notably wood, for traditional housing. This problem was and is part of the larger problem of desertification - natural resources becoming increasingly scarce; the people who depend on them aggravating the problem by "over"-consumption and being forced to search for alternatives.

Development Workshop was invited by the project to introduce domes and vaults as an alternative to the use of wood for roof-building and chose the Nubian system of construction. The reasoning behind this choice was that - where they are suitable - these techniques:

- use only locally available materials (earth and water);
- are relatively simple to build;
- are suitable for construction using unstabilized sun-dried earth bricks;
- need only simple equipment and no formwork - wooden or other;
- result in visual forms already well-known and appreciated in the region;
- are well-adapted to hot, arid climates.

Ten years after their introduction, the techniques have shown themselves to be adaptable to a variety of needs and are an accepted method of construction in an ever-growing region. Moreover, they have been adopted into the local building "vocabulary", with local masons trained in the techniques using them spontaneously, both for their own dwellings, and in response to growing demand from individuals and organizations, including state bodies. This is thus an all too rare example of a transfer of technology going beyond externally-financed projects and proving capable of being used without financial or technical assistance by local people. At the same time, this is not to deny the crucial role played by externally-financed projects, which have provided training, allowed the potential of the techniques to be demonstrated, and given them a quality image, all of which have played a part in the process of local assimilation.

This document seeks to show how, and to what extent, this assimilation of a new method of building has been, and continues to be, brought about. It also seeks to draw lessons from which other areas facing similar or parallel problems can learn.

1. Physical and socio-economic context

1.1. Geography and climate

The area in question (see map Figure 1) is located in the sub-Saharan (Sahel) and Saharan belt, and covers approximately 30% of Niger, as well as a part of N.E. Mali.

This area is characterized by low annual rainfall, decreasing sharply towards the north-east, and by its wide diurnal temperature range.

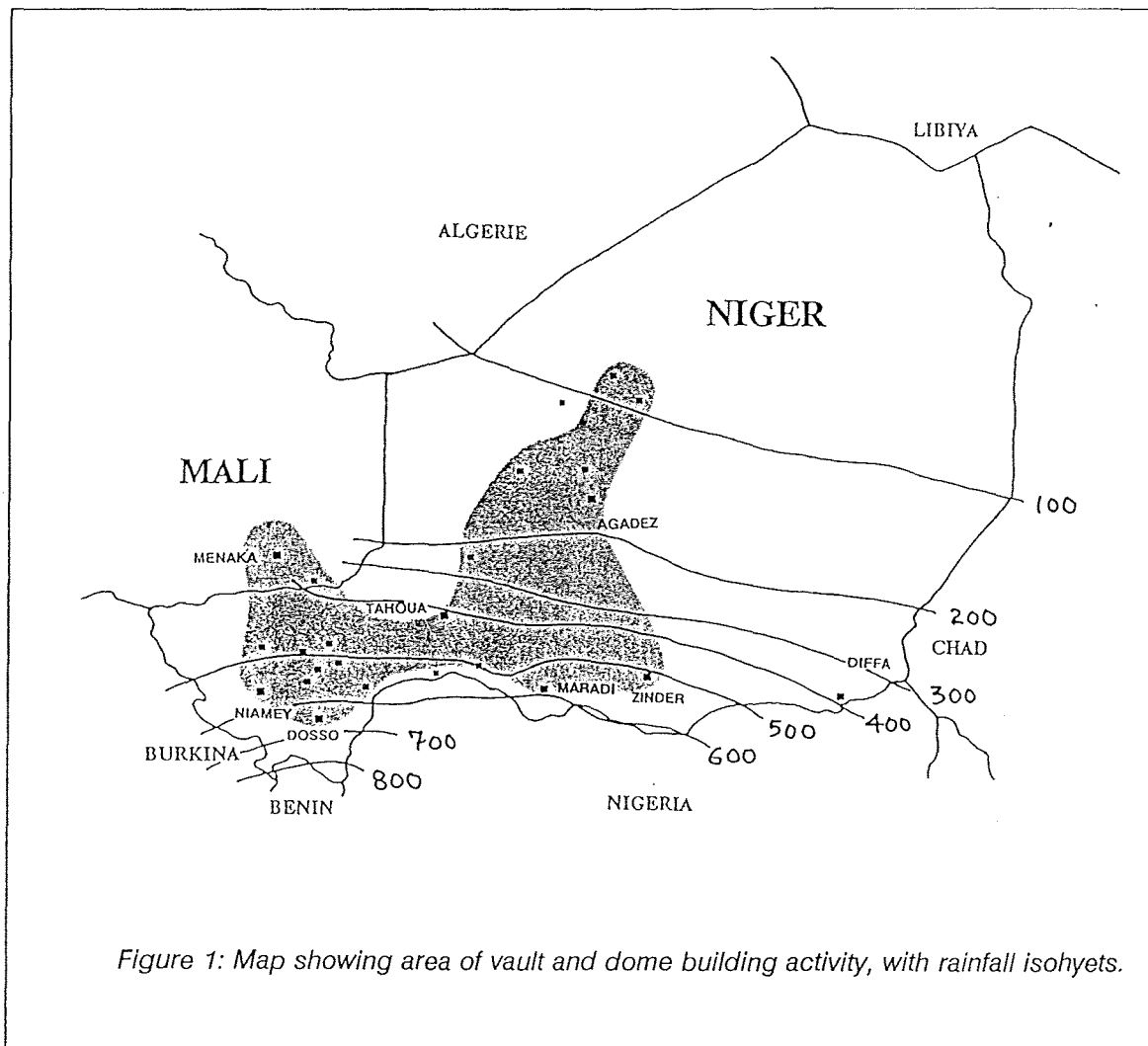

In general terms, this area has been severely affected by periods of drought, one result of which has been to dramatically reduce the availability of trees and organic material traditionally used in building, both for light supporting structures (see photo 1), and - more crucially - as timber for flat roofed earth brick houses (see photo 2).

At the same time, although average annual rainfall is low, when the rains come they tend to fall in a few short, but heavy downpours, often causing serious damage to buildings and land.



Photo 1: Supporting structure for nomad's traditional tent, Tin Telloust.



Photo 2: Recently constructed roof consisting of wooden beams and rafters, seen from above, before covering with mats and earth; south of Agadez.

1.2 Socio-economic context

The area is principally populated to the north by Tuaregs and to the south by Hausas, Kanouris and Djermas.

Especially to the north, years of drought and the growth of the desert have increasingly led a population of nomadic herdsmen, traditionally mobile, to adopt a sedentary lifestyle. This change in lifestyle has resulted in a concentration of families around wells, where gardens can be irrigated, or aid provided, and in areas where work is to be found, limited though these are. At the same time, the difficulty of survival in rural areas has led to the expansion of urban areas. Today, (1990), even though the rains have been relatively good in recent years, the number of people practicing transhumance is very small compared to what it once was.

Towards the south, population densities are higher and the main activity is agriculture.

The financial position of most people is very poor. For most families, income is low, and for many of them virtually nonexistent.

In this socio-economic context, many activities are undertaken in a spirit of mutual help, especially in rural communities. Building, for example, can be spread over several years, especially when it involves the collection of materials. It is therefore sometimes very difficult to place a monetary value on a product or labour achieved thanks to non-remunerated participation and the use of materials which are available at no financial, but often at considerable, environmental cost. Thus, as far as private sector building is concerned, especially in rural areas, it is hard to evaluate the viability of a construction method solely using the monetary criteria. Amongst others, the facility or difficulty in obtaining building materials and using them are equally important. It should also be mentioned that although it is difficult for a poor man facing a shelter problem to think of the good of the environment, there is nevertheless at all levels a marked increase in awareness that damage must be limited if any kind of viable future is to be possible.

In areas where transhumance was common in the past, the process of sedentarisation had led to the use of more permanent shelters. Light structures (tents and *paillotes* - round thatched grass-walled shelters) have increasingly - within the limitations of local availability and knowledge - been superseded by houses. In general these have walls built from sun-dried earth bricks and roofs of timber beams, rafters and laths covered with mats and earth. With the exception of one type of traditional building in the south of Niger - granaries with thin earth walls (see photo 4), once also a popular house type (8) - most traditional buildings consume significant quantities of organic materials, including grasses, straw, branches and tree trunks.

8 *The almost total disappearance of this form has much to do with ideas of modernity and prestige: a pointer to the fact that for buildings to be socially acceptable, they must do more than merely shelter, they must be a source of pride.*

2. The problem of the use of wood in building

2.1 From the point of view of development and conservation agencies

Since the 70's, a growing number of international agencies and external organizations concerned with development and conservation in the context of the fight against desertification in the Sahel consider that the unmanaged, often irrational, use of wood and organic materials is a contributory factor in the disappearance of certain plants and trees and in the general degradation of the environment.

Moreover, it is clear that where more and more construction of buildings with flat roofs supported by wood is taking place, the problem is becoming increasingly serious. This is because whereas the building of light structures such as tents and *pailloles* requires a lot of renewable elements (twigs and small branches), the building of a traditional earth house requires the cutting of non-renewable trunks and main branches. The dearth of dead trees leads inevitably to the cutting of live trees, although this is now illegal.

Hence agencies' attempts to address this problem. Where the soil and water table are suitable, there has been planting of trees, often eucalyptus, partly for building purposes. (This approach is not viable in a large part of the area with which the programme described here is concerned.) An alternative approach has been to suggest the use of alternative building techniques which reduce or eliminate the use of organic materials.

2.2 From the point of view of the local population

For local people, the problem is perceived differently.

Towards the north of the country, the inhabitants - directly affected by problems arising from drought - are for the most part aware of the degradation of the environment. Nevertheless, on a practical level, when it comes to building a shelter, a family will employ the method which is easiest in cost and efforts, from the range of options of which they are aware.

Thus, in many areas, building a simple structure with 20cm earth walls and a roof of wood, branches and earth, is still regarded as the simplest and easiest construction method, even though its performance (in terms of comfort and durability) may be poor.

Against this background, however, a recent survey (9) has shown that (with the rare exceptions of areas which have been extensively planted), the use of wood and organic materials has become increasingly difficult. The principle difficulties encountered can be summarized as follows.

Firstly, the cost of wood is rising, and the quality falling: in Iférouane, a 3.5 - 4 metre doum palm trunk cost 2,000 Fcfa in 1982, compared with 5,000 Fcfa in 1990, not counting the cost of the permit for tree-cutting (12,000 Fcfa/tree). (10)

Secondly, good quality wood is very hard to obtain: the wood which is generally available is not strong, has limited resistance to termites and humidity, and hence a short life-span. For example, good quality doum palm wood (so-called "black" wood) is now very rare, forcing builders to use either the shorter lasting "white" doum palm wood, or other species, such as *Accacia radiana*, which has an even shorter life-span and less strength. Householders are alive to the fact that they have to change the wooden roof structures more frequently (currently approximately every three years, compared with every ten to twenty years in the past), and that this pushes the cost and inconvenience up considerably over the years.

Thirdly, to obtain wood and branches, increasingly wide distance have to be covered: in Agadez, there is talk of importing wood from Gaya, 972 kilometres away. Clearly not an option for the poor.

Figure 2: The impact of the use of poor quality wood on interior room dimensions.

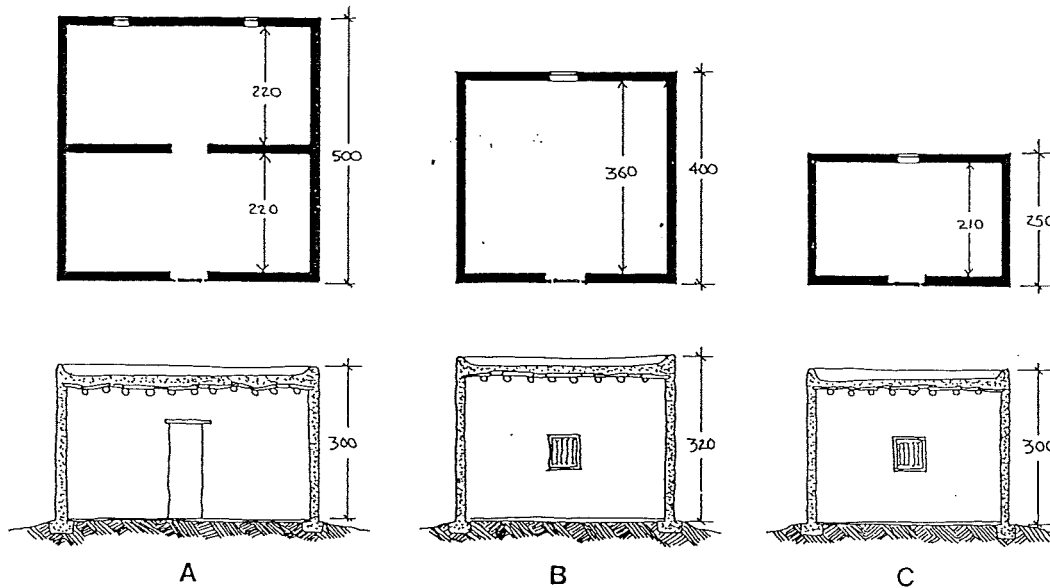

An interior span of approximately 3m 60 is desirable and was normal when good quality wood was easily obtainable. The examples A, B and C shown above were surveyed at Garbey Malonkwara (Ouallam). A and C show reduced spans because of the difficulty in obtaining good quality wood and/or at affordable prices. B shows the desirable span, built using beams which are increasingly hard to find and expensive.

Figure 3: The use of a central pillar

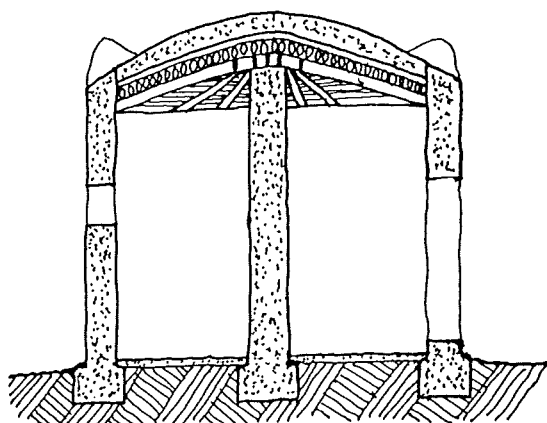

An alternative to reducing spans to overcome the absence of good quality wood is to introduce a central pillar. This seriously reduces the usability of the interior space.

Fourthly, problems in obtaining wood capable of supporting the weight of the roof over a wide span is affecting the design of the houses: rooms are becoming narrower, to the point where they can only just fit a bed. (See Figure 2). Another solution sometimes adopted is the use of a central pillar which breaks up the interior space. (See Figure 3.)

This situation has led to the people living in areas where they have been exposed to woodless roof constructions showing great interest in the techniques, as will be shown later.

2.3 From the point of view of the state

Official reports in Niger have cited the use of wood for heating, for domestic use, primarily cooking, but also for structural purposes, as being one of the causes of the process of desertification which the state is committed to combatting.

The departments concerned with the protection of the environment are confronted with the very real problem of how to control illegal cutting of trees for building. This makes the protection of forestry resources very difficult and highlights the need to put forward practical and attainable alternatives to the use of wood. The application of laws (e.g. fines or imprisonment for failing to obtain costly tree-cutting permits) without the provision of alternatives can only add to the hardships of the poor.

Hence the authorities' (11) stated desire at national and regional level to promote and support techniques for building without wood.

11 Interviews were carried out by Development Workshop in Niger in May/June 1990 with Mr. B. Rafini, Secretary-General, National Development Council; Mr. M. Mahomane, Director of Housing and Mr. S. A. Askia, Director of Urbanism, Ministry of Public Works and Housing; Mr. A. K. Hassan, Assistant Secretary-General, Agadez; and Mr. H. Dalla, Mayor, Agadez. All were strongly supportive of the vault and dome sun-dried brick technology.

3. Woodless construction: sun-dried earth vaults and domes

3.1 Background and reason for this choice

Techniques for constructing vaults and domes in unbaked earth, using no formwork, were introduced to Niger in 1980, in Chikal, south of Filingué in a training programme (see footnote 2) which included the construction of a literacy centre (see photo 3).

The techniques which were selected for this programme are of Nubian origin, from southern Egypt, where they have provided over the centuries a solution to the dearth of wood in this dry part of the Nile valley. These arid conditions are similar today to those of Niger and indeed of a major part of the Sahel.

Amongst the various building techniques of this kind (12) which do not require the use of wood, the Nubian system was selected by Development Workshop primarily because it is relatively easy to learn and because the shape of Nubian vaults and domes is well suited to building with unstabilized unbaked earth bricks. (See Figures 4 and 5.)



Photo 3: Literacy centre, Chikal, built 1980 in the course of the original training programme introducing the Nubian system for shutterless vault and dome construction in unstabilized sun-dried earth bricks.

12 *Alternative techniques for the construction of vaults and domes are to be found, for example, originating in Iran and Tunisia.*

Figure 4: The Nubian vault

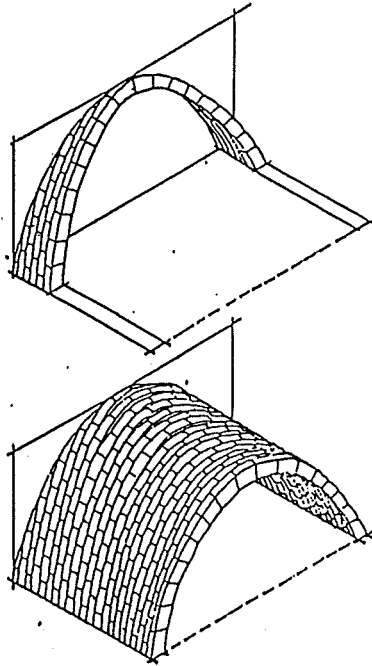

A vault in the form of an inverted catenary.

The brick courses are built up leaning against a back wall.

The shape of the vault, the slope of the courses of bricks, and the adhesion of the mortar prevent the bricks from falling during construction, without having recourse to formwork.

Figure 5: The Nubian dome

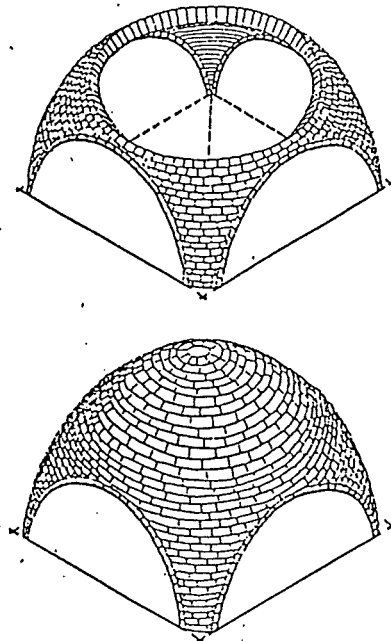

A dome made up of small roof bricks laid in horizontal concentric circles.

Rows are inclined towards the centre.

The position and angle of each brick is determined with the help of a wire or radial arm rotating around a central pivot.

The domes can be used to cover a range of shapes, usually round or rectangular.

Moreover, vaults and domes are familiar forms in Niger, where two main systems of construction have been used over the years. For palaces, mosques and private houses, domes or (rarely) vaults were built of earth supported on a wooden armature (see photo 4). Granaries and small dwellings were built of earth in the same way that coiled pots are made so that the result is a thin continuous earth shell (see photo 5).

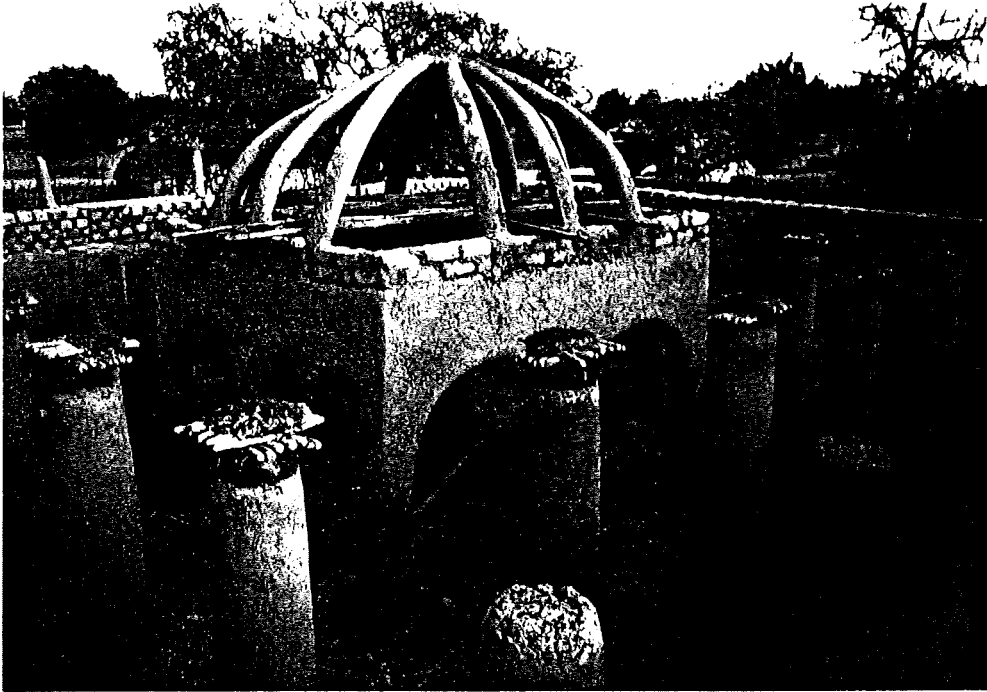

Photo 4: Wooden armature of traditionally built domed building.

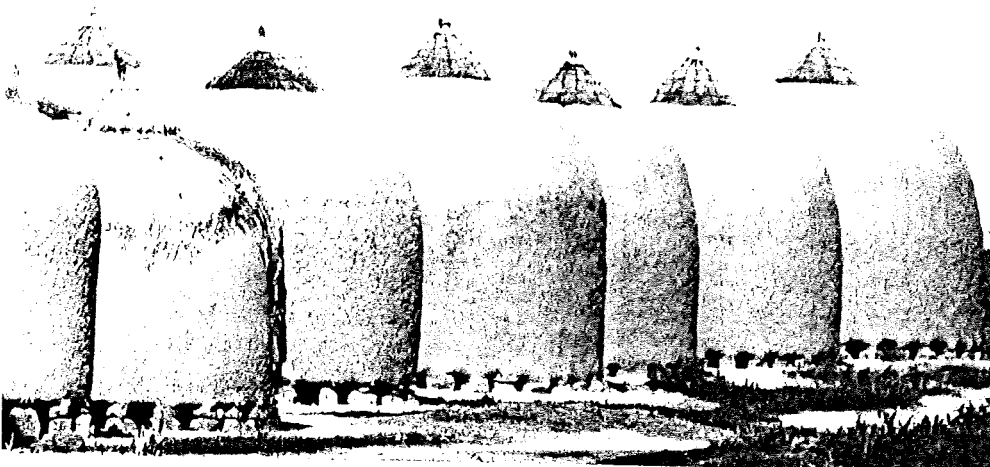

Photo 5: Granaries, with thin mud walls, built with earth and organic fibre.

3.2 The objective of this transfer of technology

The introduction of these "new" techniques of building in sun-dried bricks had the following objectives, apart from those outlined above:

- To enable the inhabitants to have access to techniques suited to the local climatic and socio-economic context and to the available resources; the techniques are suited to building both *casas* (typically small, round, one roomed houses) and larger houses when traditionally used resources of wood and organic matter are no longer easily available.
- To allow the building of medium-sized public buildings in areas which local material and climatic conditions are appropriate to the techniques.
- To promote the local economy and local skills by using materials and builders from the area for the construction of public buildings which would otherwise frequently be built with a high proportion of imported materials such as cement and using external qualified labour. (Methods using "modern" materials have a cost structure heavily biased away from labour towards materials: this is economically illogical in a country which has no alternative but to import such materials, or the energy to produce them, and which has much under-utilized labour.)
- In a very general sense, to provide an example that man is not a slave to nature, nor *vice versa*; by searching for and developing solutions, balance can be achieved.

4. How were the techniques introduced?

4.1 "On-the-job" training

Until 1987, the introduction of these vault and dome building techniques has been achieved in the context of various programmes linked to rural development and to the management and conservation of local resources. "Training" has been mainly "on-the-job", with builders of widely varying experience and qualifications working on the construction of one or more buildings. Thus although building needs provided some opportunities to train people, the primary objective was often to build rather than to train. As a result, for complex tasks, experienced builders tended to take over, leaving "apprentice" builders to one side.

In most cases, (and especially during the first six years following the initial 1980 training programme), the buildings worked on by trainees were relatively large. They consisted either of public facilities (e.g. the meteorological station and the literacy centre in Chikal - photo 3), or of project infrastructure buildings (including offices, guest houses and housing for project personnel - for one example see photo 6). Efforts have been made all along to provide examples relevant to local people and to support any local initiatives, but not until 1987 did the PAT train builders specifically in building small dwellings similar in style and size to local homes. (See Appendix 5.)

Training "on-the-job" has certain other drawbacks. The building of a single structure does not allow all the trainees to be trained in all stages of the building process - from laying out to finishings. This is because if there is no opportunity for repeating the same operation several times (laying out, choosing a brick pattern, building the vault or dome etc.), the builder will emerge with an incomplete training. He will tend to have a good grasp of the principles of the roof structure, but a poor overview of the complete process. This is a serious deficiency, since it is particularly important that the complete process and the importance of each element is well understood. It is no use - and indeed positively dangerous - knowing how to build a vault or a dome without knowing also how to build adequate foundations and strong walls.

This grasp of the whole process can also pose an unnecessary problem when the building is a large one, with little in common with the private building needs of the builder's own village.

4.2 Demonstration buildings

Although relatively large buildings (such as project or public infrastructure buildings) may not be entirely suited to practical training, they nevertheless play three key roles:

- they demonstrate the possible applications of building techniques;
- they give them a quality image;
- finally, and significantly, they give trained masons the chance to continue to gain experience after their initial training.

It is noticeable in areas such as Iférouane, where there are numerous examples of this type of construction, that the forms and techniques are more readily assimilated by the local population and by the builders. Demonstration and the multiplication of built examples is thus an important element in the introduction of these techniques.

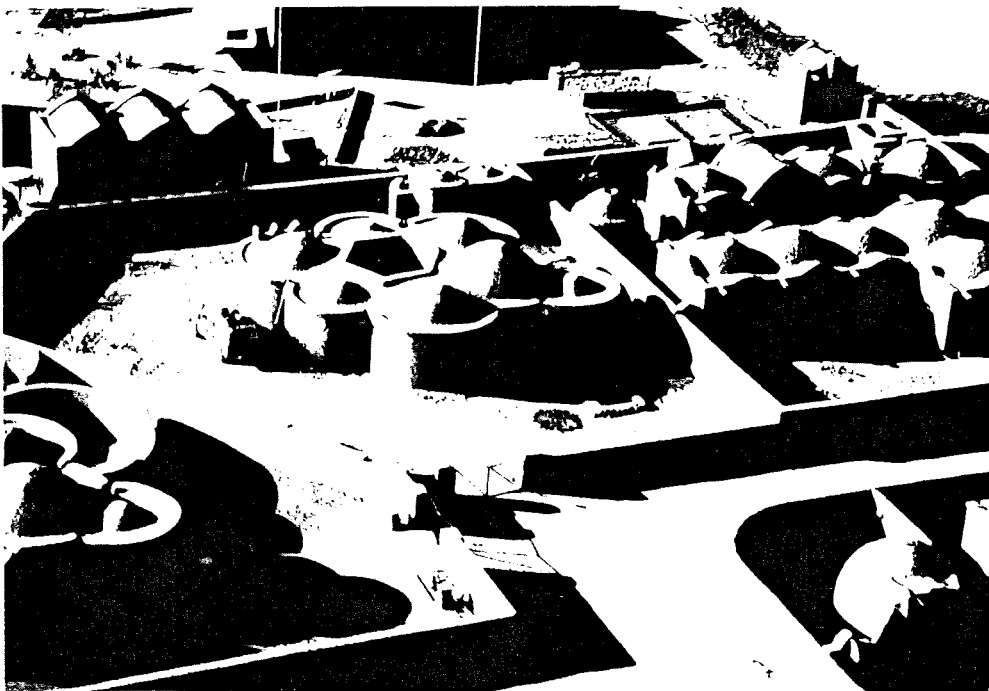

Photo 6: PAT personnel housing and infrastructure, Iférouane; part of the project headquarters complex.

Larger public buildings etc. in vaults and domes have the direct benefit that they are (local) labour intensive, the local people find employment, and take pride in the results. A public building (e.g. *gendarmerie*) built by them is "theirs"; one built in concrete and corrugated iron to the profit of an external entrepreneur has not got the same value.

4.3 Builders' training programmes

Dedicated training programmes with practical exercises of construction, analysis, knocking down and rebuilding are so far rare. Similarly, builders have received little theoretical training.

However, recently various organizations (13) have organized such training programmes. During one organized by the PAT in 1988/89, builders were given sessions on the theory; went on, working in pairs, to practical exercises: trying out bonding patterns in miniature scale bricks, lay-out practice, building low walls and small vaults (see photo 7) etc.; and finally went on to build a small round *case* with a domed roof. Each team had therefore been responsible for decision-making at all stages of the building process and had also the satisfaction of producing a tangible finished result. (The unusual situation of being encouraged to put up and take down brick-work as part of the learning process was invaluable. In normal circumstances, there is much resistance to taking down bricks once laid; this does not favour spontaneous learning or experimenting.) The trainers noted a significant improvement in the understanding of the techniques amongst the builders and subsequently better quality work on real sites.



Photo 7: Training programme, Iférouane: practising vault building.

4.4 Technical support tools

Over the last two years a major effort has been directed towards documenting the experience gained. On one level five dossiers on various technical aspects of the programme have been published aimed at fellow-professionals in this field. (See Annex material.)

On another level, an illustrated manual, *Les toitures sans bois* (Woodless roof construction), has been prepared (see Annex documents). This manual is aimed at certain specific groups: people who wish to be better informed about the techniques in order to decide if they might meet their building needs; individuals who have received training; and personnel responsible for building programmes whose builders may have received such training. (In practice, as far as the latter target group is concerned, the manual is already proving valuable in the common situation where projects or businesses have literate but non-specialist staff and trained builders who use the manual as a team, complementing each others' skills.) The manual is under no circumstances intended to be free-standing, but rather a complementary tool.

Finally, a key element making the construction of larger, more sophisticated buildings feasible locally has been the elaboration of appropriate "architectural" plans and worksheets enabling local masons to seize rapidly the main elements of even apparently complex buildings and lay them out and build them with ease. (See Appendix 1.) The use of these plans demands only a relatively low level of literacy and no architectural or engineering skill. (A typical example of their use might be by a trained builder with a literate son.) They have now been widely tested on a range of buildings and have been important in contributing to the "spontaneous" spread of the techniques (see 5.5 below).

5. Achievements to date

5.1 Buildings constructed

Ten years after their introduction in Chikal, the survey carried out in May/June 1990 found some 191 buildings in Niger (as well as 116 in Mali) built using these techniques. (See Appendix 2 for a full list of these.)

5.2 Trained builders

At least 100 builders have received training, either "on-the-job" or on dedicated training programmes, and have achieved varying levels of skill. Some 20 are now very experienced and capable of realizing small and medium-sized buildings unaided, including design. Some have achieved an outstanding mastery of the techniques, amongst them Moussa Amgar from Iférouane and Mouloul Amoumoun from Tchirozérine. (See "profiles" on pages 24 and 30 respectively.)

Another mason, Mallam Abdou from Ichiguine (see "profile" opposite), with little formal training, but with considerable moral support, is now building some of the finest of these types of building in Niger.

Mallam Abdou: a deeply held conviction

Mallam Abdou, a 60-year old Hausa man from the village of Ichiguine, in the Filingué area, has been a builder all his working life. A deeply devout Moslem, he is a religious teacher and traditional doctor who is well respected both locally and further afield.

In 1983, M. Abdou heard of the woodless construction techniques from a member of PTV, expressed interest, and said that he would visit the building work in Chikal for himself.

True to his word, shortly afterwards he arrived (on horseback). At the time, the PTV guest-house was under construction. Clearly impressed by the potential of the techniques, M. Abdou asked if he could join the work crew. He did so on a minimum builder's wage. After the guest house was completed, he went on to participate in the construction of a small private house (two rectangular rooms with vaults) in Chikal Ilela.

After this initial experience, he had confidence in the structures and in his own ability to master the techniques. Furthermore, he was perhaps unique locally in his deeply held conviction of the need to conserve wood: for him, using wood was bad for the environment and had in any case only a limited future. Nubian vaults and domes offered a possible solution.

On his return to Ichiguine, assisted by his sons (also builders) and his regular work partner, M. Abdou constructed a 4-room building (8m x 7.2m) as housing for two of his sons, using vaults for the roof. As none of the others had ever seen a vault before, it is not surprising that the first vault to be built was irregular to say the least. Peter Tunley was able to give advice and support on site, and the very strong desire to build well ensured that the standard of work improved dramatically.

Since then, M. Abdou has continued to build a wide variety of buildings using vaults and domes, both in his own village and further afield, for members of his family, friends, neighbours, and the community. A visitor from Nigeria asked him to travel there and build him a 4-domed house in Gulma, near Argungu. (Latest reports are that although some of the neighbouring flat roofed houses collapsed during heavy rains, his was not damaged...)

In 1990, the villagers of Bankoukou, having decided to build a mosque, asked M. Abdou to design and build it using his "new" building techniques. The result - four Nubian vaults resting on a series of arches - demonstrates M. Abdou's sound understanding of structural, climatic and aesthetic considerations. (See photos 8 and 21.) The villagers' confidence has been amply repaid in a building of great beauty, of which they are justly proud.

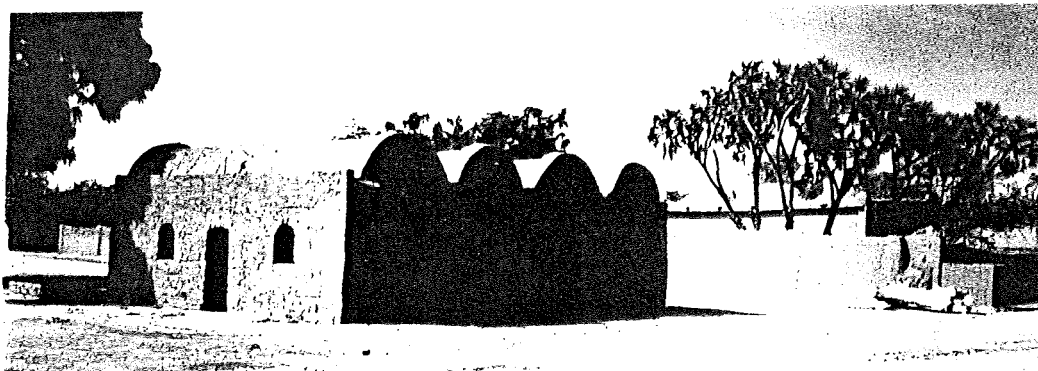

Photo 8: The mosque at Bankoukou, designed and constructed by Mallam Abdou in 1990.

All M. Abdou's buildings have been privately financed and he has received no external financial support or incentives. He is keen to learn of improvements and adaptations introduced since 1983, and intends to send his sons - every bit as keen - for further training as soon as it is available, even if it means their having to travel long distances.

5.3 Organizations promoting and spreading the techniques

Following the original training programme in 1980, at least ten local and international organizations have been active in spreading the techniques of vaults and domes in sun-dried earth bricks. These initiatives can be divided into two types:

- Activities the primary intention of which is the promotion of the techniques by organizations with an specific programme for "woodless construction" (14). These activities include the training of builders, the construction of a significant number of buildings and technical inputs on behalf of other organizations.
- Secondary activities, consisting mainly of sending builders to training courses and building a limited number of buildings (15).

The maps opposite (Figures 6 and 7) show that the spread of the techniques is mainly due to the efforts of projects with a specific programme for woodless construction:

- PAT which has had 16 other "clients" for training and/or construction and
- PTV, which has had 8 "clients".

Peter Tunley, Development Workshop Associate, who was responsible for building for PTV from 1980-84 and for PAT from 1985-90, was directly involved in some 70% of these activities.

Similarly, in Mali, World Vision has played the same disseminating role, organized by their Director and a highly motivated Malian (Tuareg) supervisor/trainer, himself trained by the PAT.

5.4 Clients

The combined efforts of these organizations have resulted in the construction of approximately 242 buildings in Niger and Mali over 10 years, i.e. some 79% of the total number of buildings constructed.

Of these, two-thirds were project-financed, and one-third paid for by clients, principally other organizations, and in a small number of cases the state.

It is important to appreciate the wide range of buildings which have been constructed.

14 *PAT and PTV in Niger; and World Vision's programme in Mali.*

15 *These include EIRENE - Christian International Peace Service; DED - German Voluntary Service; Kruger - Danish Aid contractor; ILO - International Labour Organization; PGRN - Natural Resources Management Programme, Swiss bi-lateral aid; USAID and Ministry of Public Works, Niger; U.S. Peace Corps; CAMS.*

Figure 6: Spread of "clients" (for building and/or training in vault and dome technology) of PTV 1980-84 and PAT 1985-90.

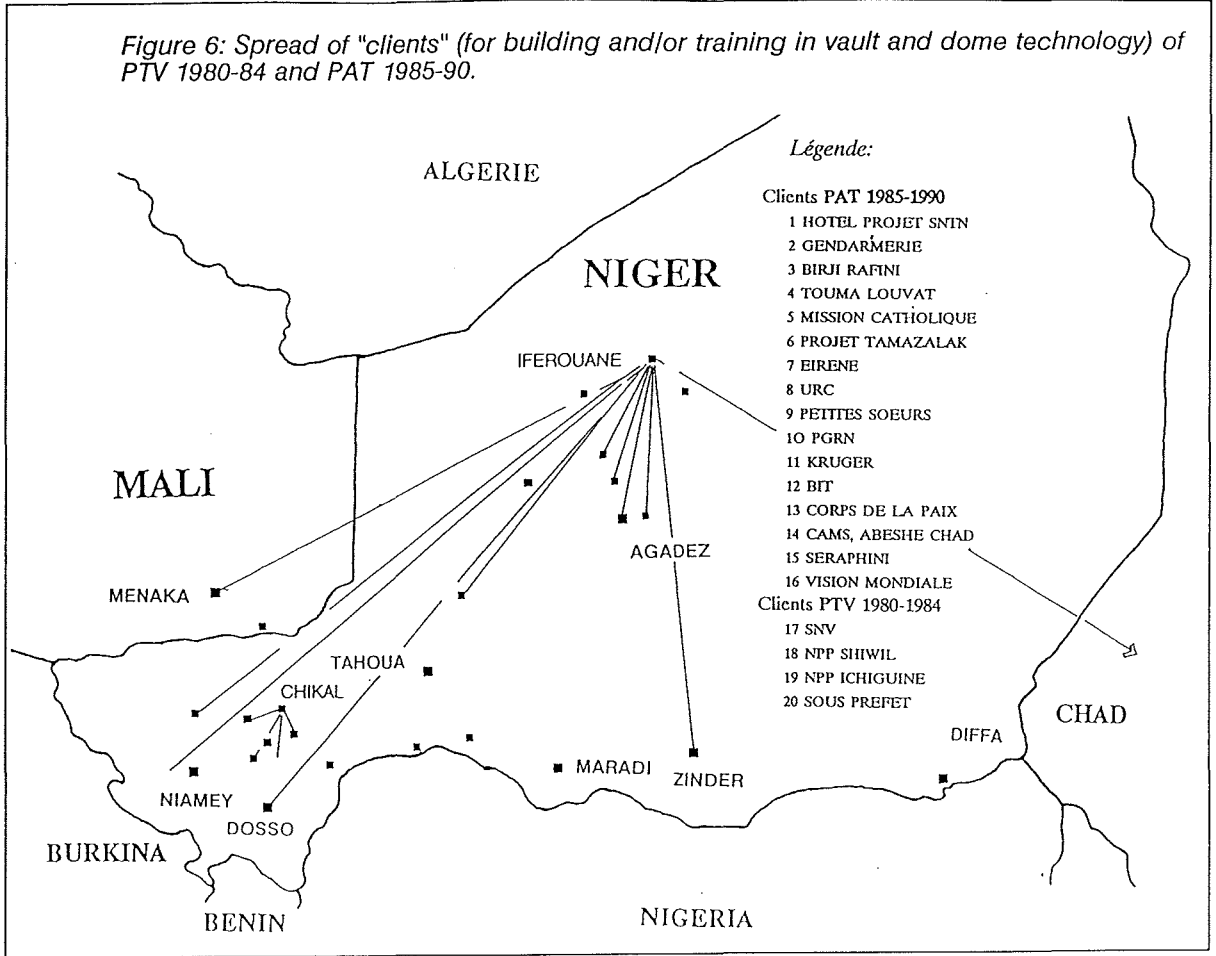
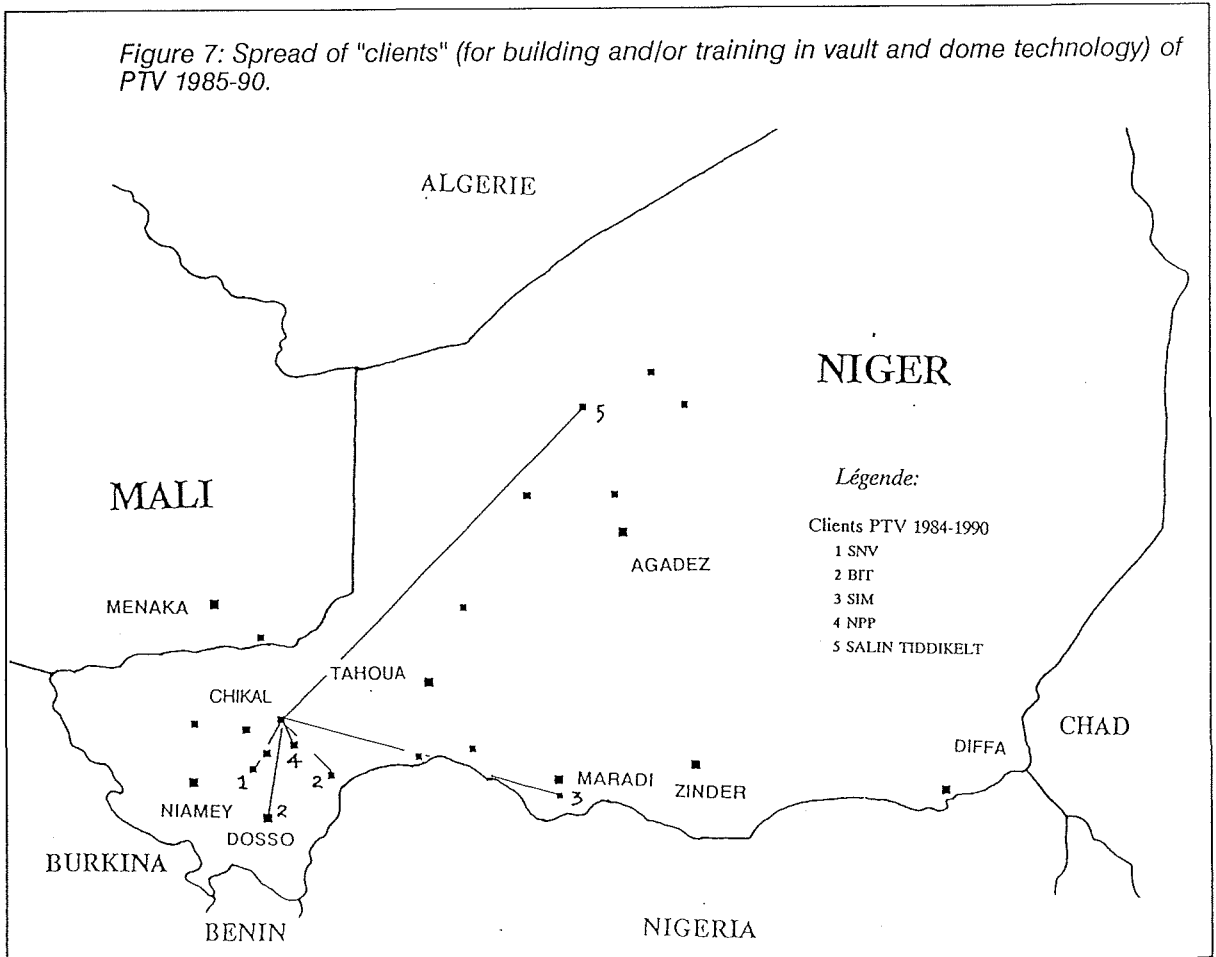

Figure 7: Spread of "clients" (for building and/or training in vault and dome technology) of PTV 1985-90.



State interest is now beginning to be translated into practical applications: the National Police Guard complex (*Gendarmerie Nationale*) in Iférouane was recently commissioned and built by local builders using these techniques.

Project buildings include offices and infrastructures, and the PAT has recently built a tourist and craft centre in Iférouane (see photos 9 and 10) using the techniques. These buildings are important, showing as they do the potentials of the techniques on the one hand and on the other serving as an example and a quality image to the authorities and to local people.

In parallel, builders trained by PAT have built 7 villas and large housing units, using plans provided by Peter Tunley, including 3 commissioned by influential private clients.

Together these buildings show the potential of the techniques for public service and private buildings.

Apart from these relatively large buildings, however, emphasis has also been placed - particularly in recent years - on the construction of small, 1 to 3-room buildings. Many of these have been built with varying functions: staff housing, guest houses, kitchens and stores, offices (e.g. for the *Conseil Villégois de Développement* - Village Development Council - in Iférouane, see photo 11).

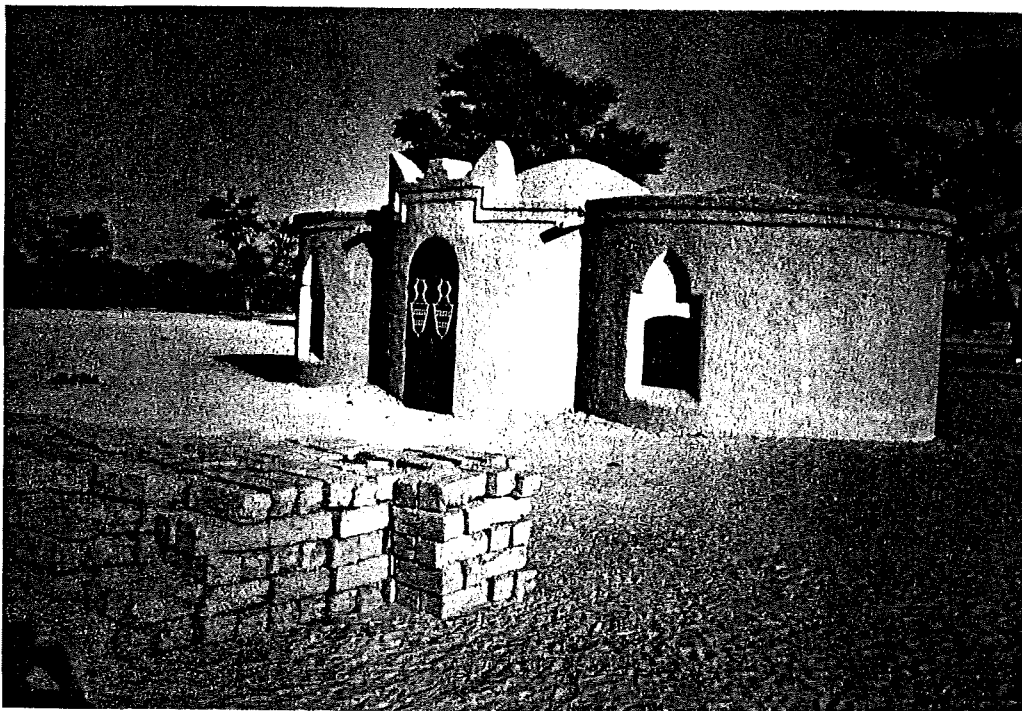

Photo 11: Community building, Village Development Council, Iférouane.

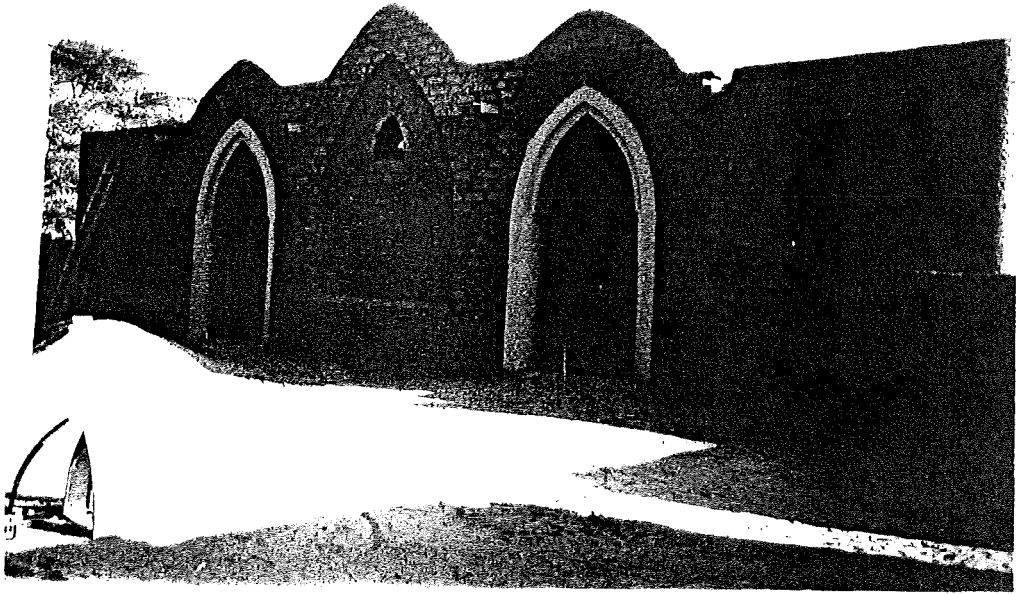

Photo 9: Tourist Centre, Iférouane.

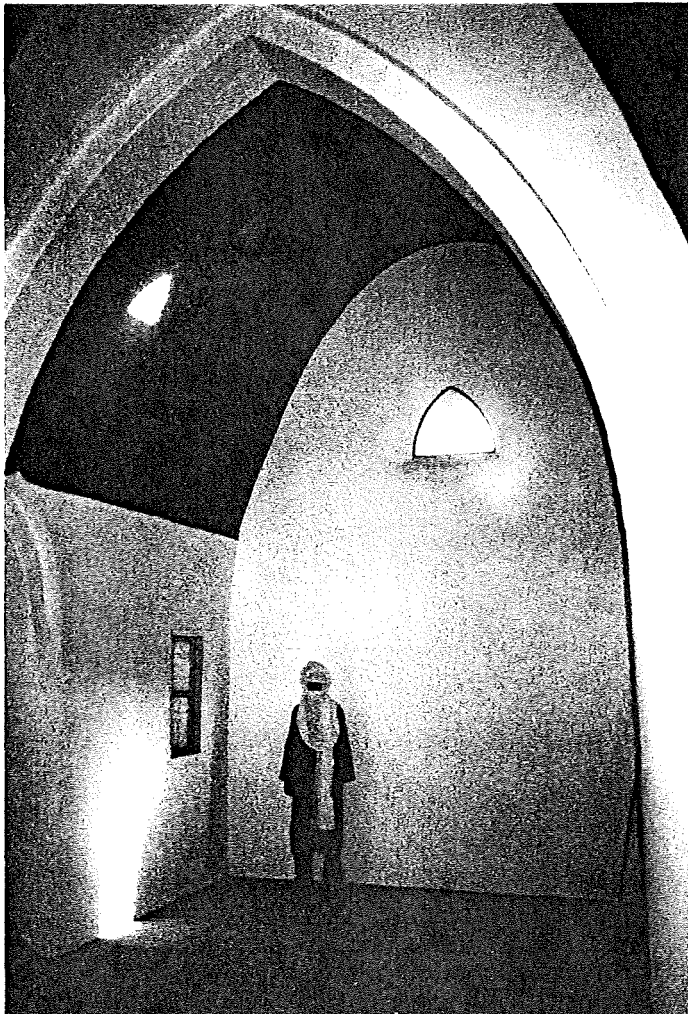

Photo 10: Interior, Tourist Centre, Iférouane.

5.5 Spontaneous construction

By "spontaneous" construction we mean any construction undertaken by local builders and financed by local householders. These are nearly always small buildings, with 1 to 3 round or rectangular rooms. More and more of these buildings are now appearing, generally going up with no technical assistance, or at most with a sketch or outline plan provided by a project member or another more experienced builder.



Photo 12: "Spontaneous" construction, Tchirozérine.

In June 1990, 5 "centres" of spontaneous building were identified:

- Chikal with 5 buildings;
- Ichiguine and Bankoukou with 8;
- Iférouane with 18;
- Tchirozérine with 4 (which represents two thirds of the buildings constructed over one year);
- Menaka (Mali) with 22.

It must also be remembered that - as in the case of Iférouane, Tchirozérine and Ichiguine, the "main" (project-trained) builders (16) themselves are training "apprentices" amongst members of their family, with their friends acting as labourers working on site. It is significant that there are now young men who can build vaults and domes who have never built a flat roof.

The enthusiasm of the builders using the techniques plays perhaps at this stage the most important role in the spread of spontaneous construction. They need no convincing of the global benefits of the "new" building method:

- no more problem of obtaining wood;
- no termite problem;
- a simpler building process (given that the whole building is made out of the same material);
- a cleaner living environment, due to less insects and dust;
- and last but not least, less damage to the environment.

Householders are also aware of these benefits.

At the same time the presence in any given area of "demonstration" buildings (constructed by a project or otherwise) facilitates the acceptance of the techniques amongst the local population.

Conversely, two same two factors can slow the process of acceptance, i.e.:

- an absence of models and
- a lack of trained builders.

During the early stages of introduction, trained builders - being relatively few in number - can command high rates for their work, too high for most local means, and in any case they have often been occupied full-time by meeting project building needs.

This situation will undoubtedly improve as the numbers of trained builders grows and they compete for work.

Moussa Amgar: an enquiring mind

Born in Iférouane to a Hausa father and Tuareg mother, Moussa Amgar, 35 years old, first came across Nubian vaults and domes in the course of the construction of the office and infrastructure buildings of PAT, in Iférouane, which was also being used as a vehicle to train local builders. (See photo 6.)

Like most men of the area, he has travelled a great deal; with a wide building experience in Algeria and Libya, he and his small team of masons had been building rectangular flat-roofed houses for some years.

During the construction of the PAT complex, an attempt was made to encourage questioning by the workforce, in order to try to develop understanding of the principles behind the techniques, rather than just give instructions. Moussa responded quickly to this approach, so much so that when the PAT buildings were complete he asked for plans for a 3-room domed and vaulted house, which he then built without financial or technical assistance.

At the same time, Moussa realised that he still had much to learn and kept his enquiring attitude. This is significant, as all too often builders given initial training consider themselves to be fully-fledged experts. This attitude can be dangerous: local conditions and materials vary from place to place, no solutions are standard, and the builder must consider each new building afresh.

When PAT building activities continued in Tin Telloust, Moussa became site supervisor there. At this time, a search was being made for ways to make the buildings stronger, simpler and cheaper to build. Progress was made: the gothic (or pointed) dome was introduced and the first dome on a round base built. Both innovations were popular, but it was Moussa who, during a lull in project activities, was the first to build domes on a round base for his own family. (See photo 14.) His own confidence, his strongly held belief that people can influence their own future, and his total integrity have been an inspiration to others and encouraged many to follow his example.

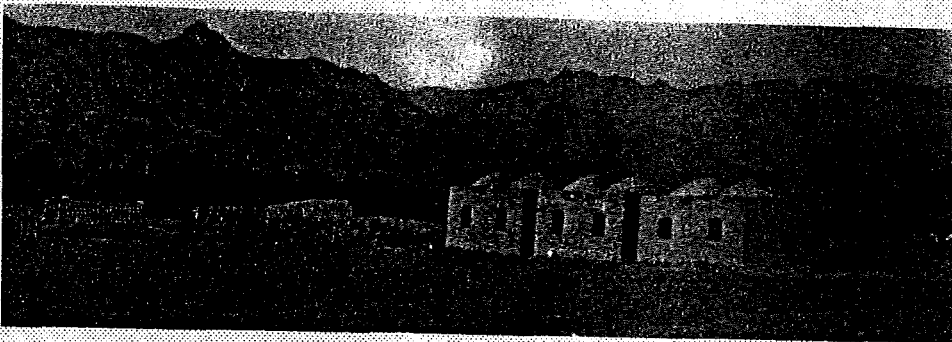

Photo 15: Travellers' lodgings, designed and supervised by Moussa Amgar, Iférouane.

Since then, M. Amgar has continued not only to build and to train, but also to seek new solutions to meet the needs of different sites, functions, and tastes. This is why he has been able to turn his hand equally well to the building of small rock barrages and of wells, the latter using newly-introduced small curved bricks. With his open-minded attitude, he has been invaluable when working outside the Iférouane region; thus, during the recent construction of a cooperative in Agadez, he ensured a dialogue with local builders, enabling a fruitful exchange of ideas.

Although able to understand and use building plans, Moussa is handicapped by the fact that he is not literate in Roman script. He hopes that literacy classes will soon rectify this.



Photo 13: Private houses (2 round rooms, with domed roofs) built by Moussa Amgar and his team, Iférouane. (For actual costs of these buildings, see page 32, House type 2.)

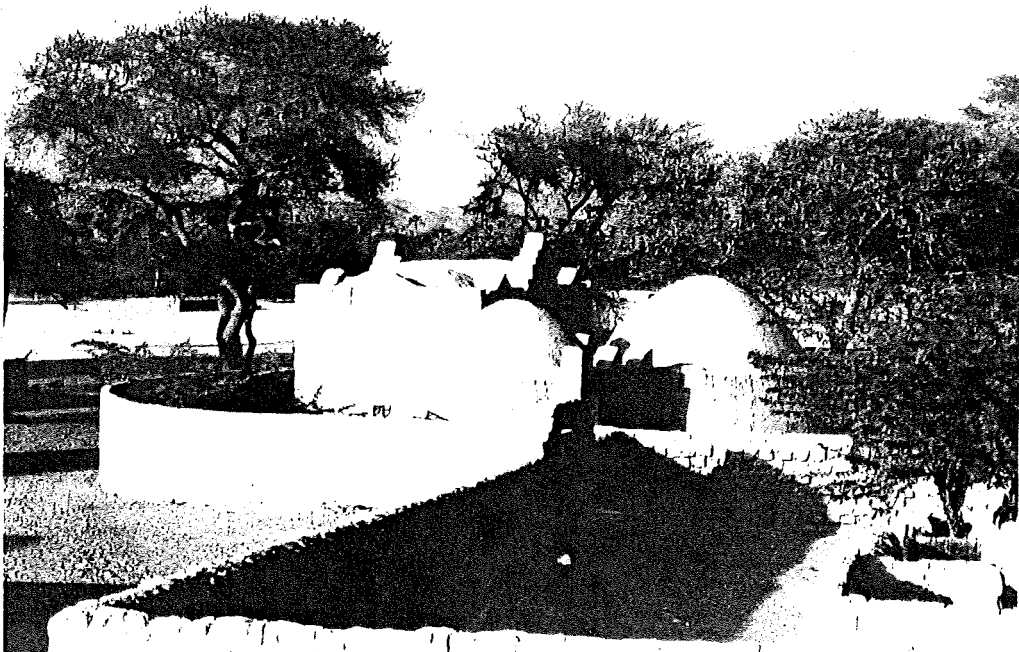

Photo 14: Moussa Amgar's private house, Iférouane; domes on round bases.

5.6 The quality of achievements so far: strengths and weaknesses

The June 1990 survey visited most of the buildings put up over the last ten years (see Appendix 2 for a complete list).

Out of some 307 buildings in Niger and Mali, 297 are in good condition, (i.e. displaying no structural problems, despite in some instances minor technical deficiencies), although some of these are in need of maintenance (e.g. the literacy centre in Chikal, built in 1980, needs rerendering). 5 buildings have been damaged as a result of structural problems, with partially or completely collapsed roofs. Cracks were observed on 2 more buildings which may lead to more serious problems in the future.

These instances have highlighted weak points in both understanding of the techniques and in their practical application, notably inadequate foundations and poor bonding patterns.

Overall, however, the quality of construction of the vaults and domes themselves is good. For vaults, construction has been simplified by the use of guide strings assuring the alignment. (See Figure 8.) For domes, the introduction of Gothic or eccentric domes has made them simpler, stronger and more esthetically pleasing (See Figure 9.) The high quality of building of the vaults and domes can also partly be attributed to the fact that training would naturally tend to focus on these elements, rather than on the supporting structures and finishings.

Figure 8: Extract from the manual "Les toitures sans bois", showing the use of guide strings for vault building.

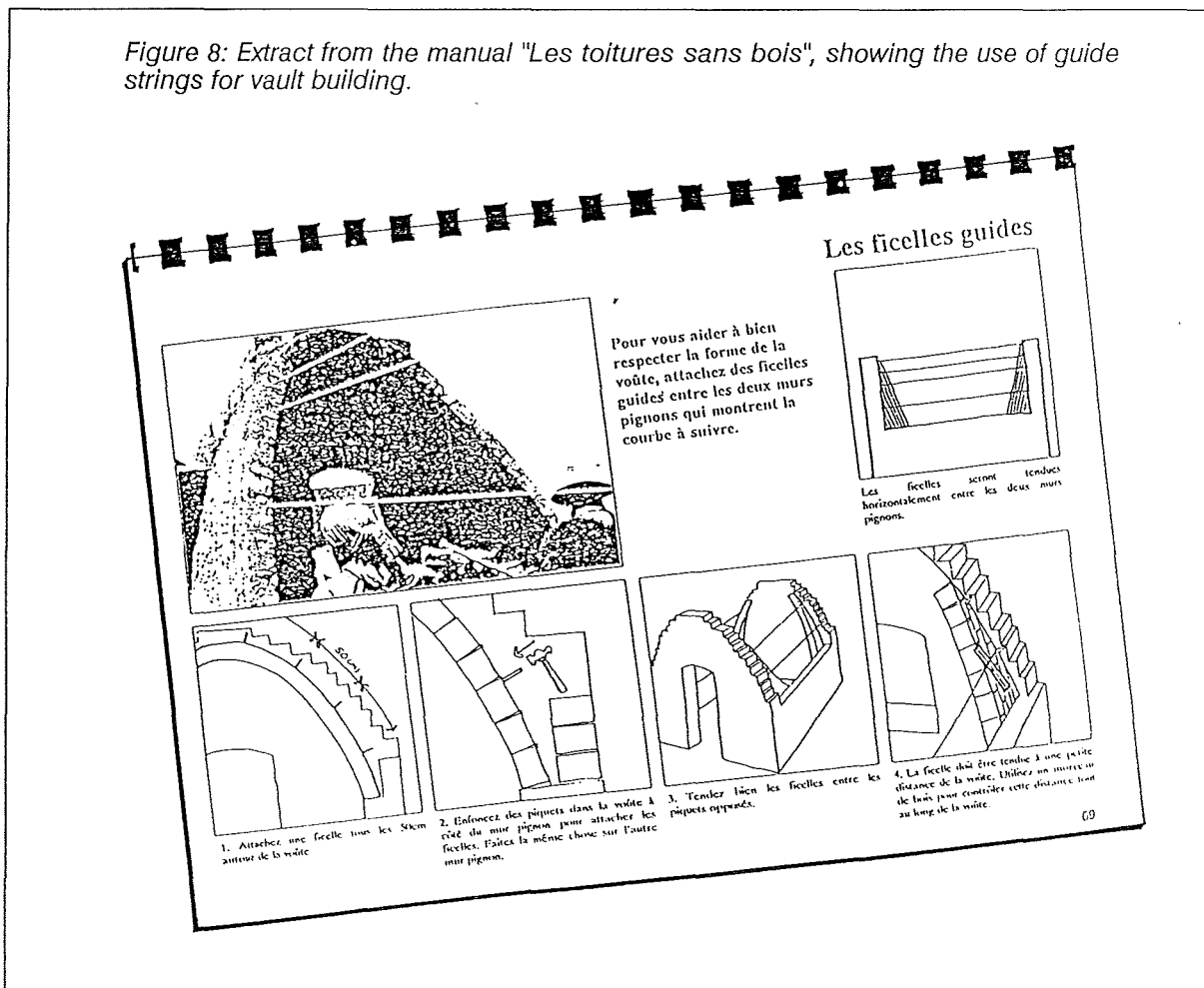
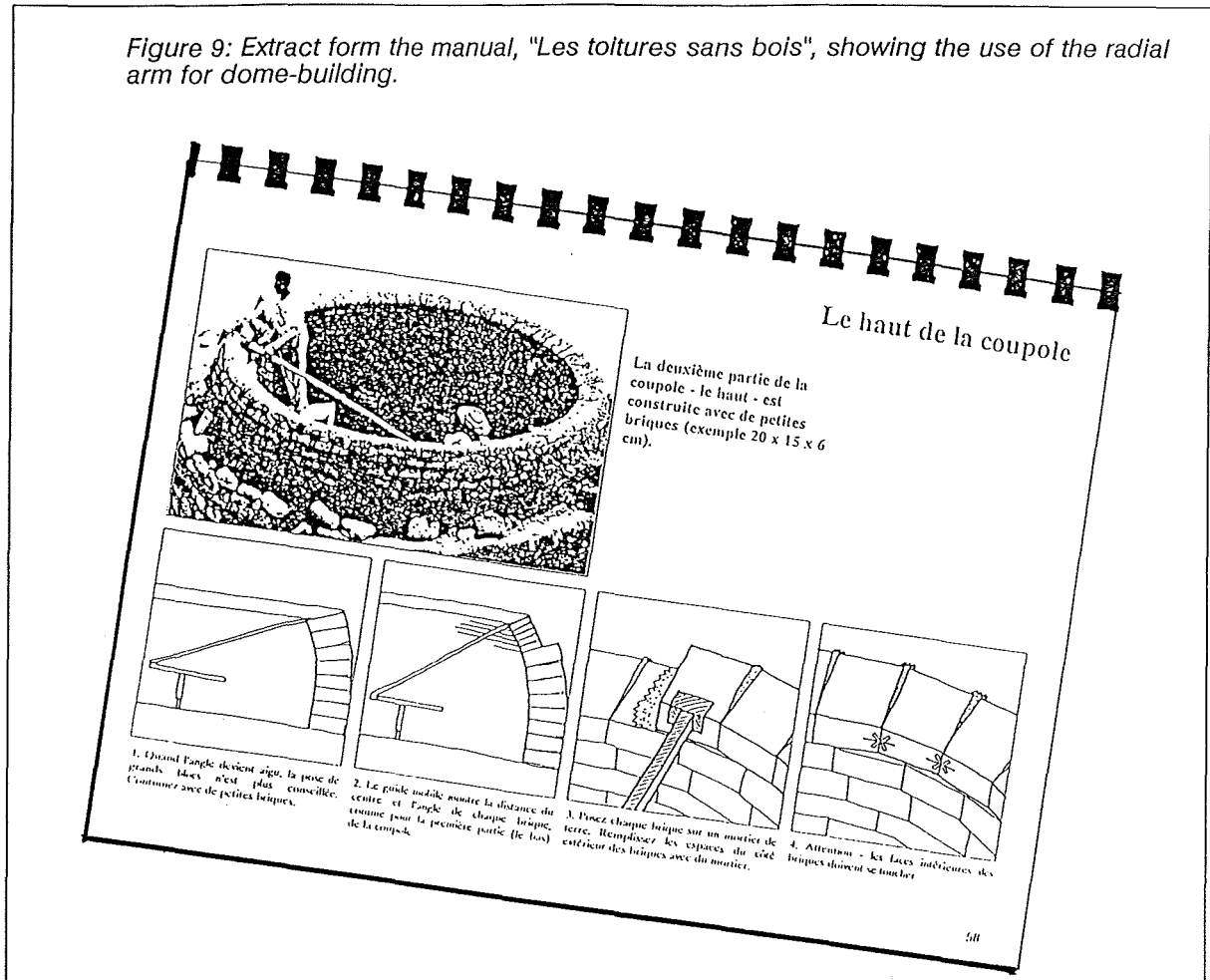

Figure 9: Extract from the manual, "Les toitures sans bois", showing the use of the radial arm for dome-building.



Problems identified arose mainly in 5 areas:

inadequate - or even absence of - foundations;

poor wall-building, especially bonding patterns, leading to weakness in the corners of rectangular buildings, and above all to cracking in domes built over them;

the dome is built up too fast, leading to slump which exerts extra pressure on the supporting walls;

insufficient attention paid to draining off rain water, either because of the design of the roof, or inadequate gutters which block up too easily;

poor rendering: either badly prepared earth renders, or cement renders which crack and which, having allowing it to penetrate, trap water, often leading to serious problems.

These problems can be attributed to three factors:

training which failed to place sufficient emphasis on these 5 areas, and failed to make clear the behaviour of the structure of domes and vaults in the overall structure;

poor quality workmanship or site supervision;

"pressure" applied either by the client or the site supervisor in order to economize on materials or speed up construction.

These problems can be addressed by better training of the builders themselves on the one hand, and a better general understanding of the principles behind the techniques on the other, as well as by better quality control.

It should also be noted that failure of certain buildings has not discouraged builders or clients: people are used to the failure of poor quality work and have not attributed problems to the building technique themselves. This underlines, however, the need to be able to refer to good basic reliable examples.

5.7 The evolution of forms

Since the construction of the first building, the literacy centre in Chikal, the style of the buildings has evolved. This evolution is particularly clear in the detailing of doors, windows and parapets. (See photos 16 and 17.) Individual builders are also beginning to evolve their own style, another indication of the genuine appropriation of the techniques, and therefore a very positive advance. (See photo 20.)

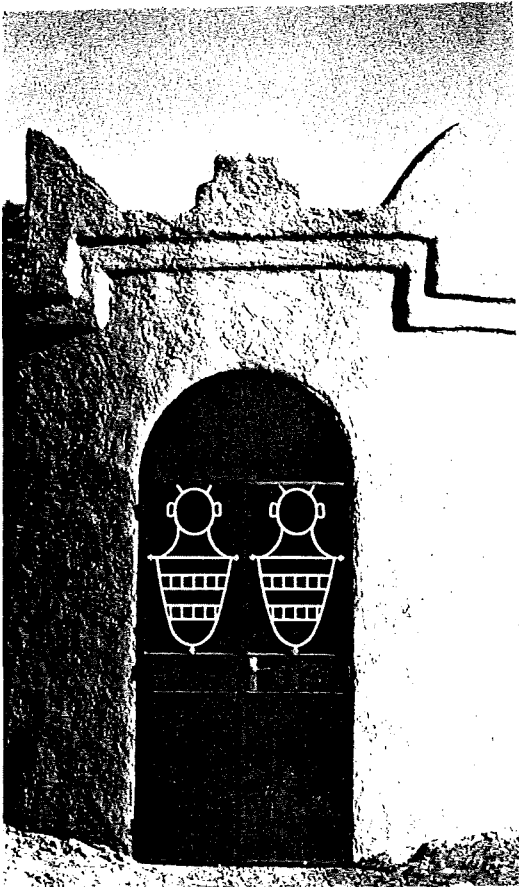

Photo 16: Door of Village Development Council, Iférouane.

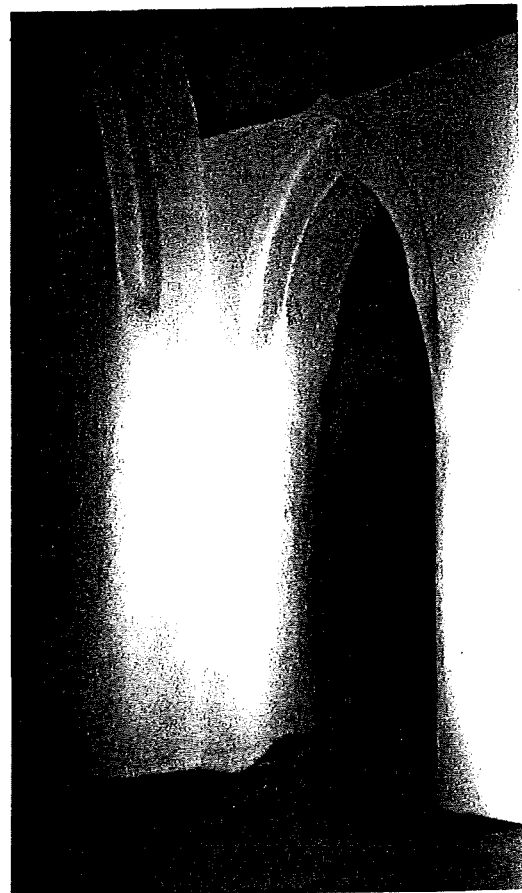

Photo 17: Interior detail of doorways Tourist Centre, Iférouane.

Two examples of the attention typically paid to finishings.

At the same time, the evolution of structural forms are at least as important as purely esthetic considerations.

Thus a new round domed *case* has been introduced (17). This is on the one hand simpler to build, and therefore more accessible to the poorest people, and on the other reduces the risk of poor bonding (having no corners they have no stress concentration and hence less risk of failure). The round building is also simpler to lay out and allows economies to be made in materials and labour-time. This simple model can also be used to create buildings with two or indeed multiple rooms. (See below.)

From simple cases to villas....

The new round domed case adapts itself to small buildings and to the design of sophisticated villas.

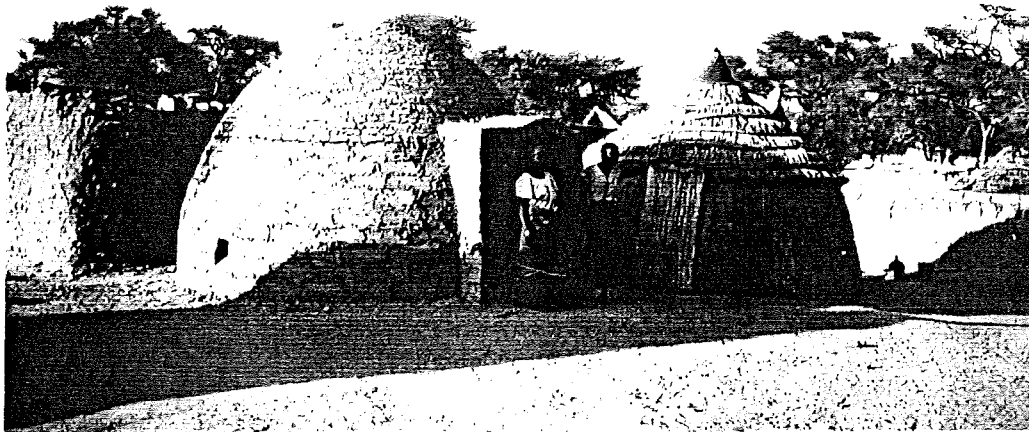

Photo 18: Simple structure, designed to be built by women as a replacement for the "pailote".

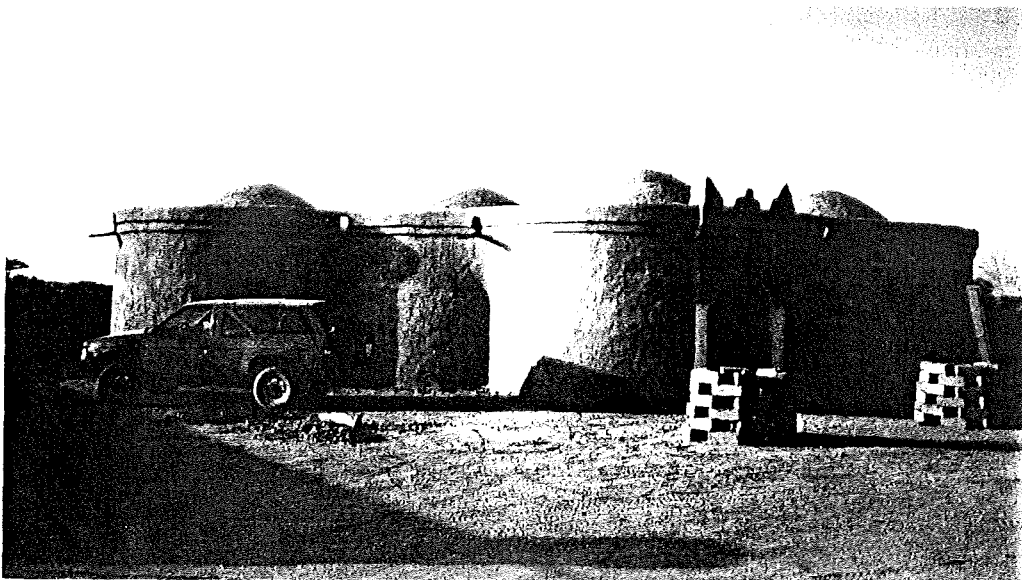

Photo 19: Private house, (Villa "Louvat"), with 9 rooms, Iférouane. (See also photo 21a for interior.)

Mouloul Amoumoun: how to satisfy a growing demand?

Based in Tchirozérine, Mouloul is a self-employed builder, living in a two-domed house he built himself. He readily accepts that other builders work alongside him to learn how to build vaults and domes, as he considers that this is the only way in which the growing demand for these buildings will be satisfied. How did he come to be in this situation?



Photo 20: Decoration above doorway, Mouloul Amoumoun's own house, Tchirozérine; this is also now his "trademark."

From his first day it was obvious that the techniques made sense to him and that he was determined to understand and master them. He also had the advantage of being literate, and was able to take notes and read simple plans.

On his return, he built two buildings for EIRENE: a 3-domed staff house, and a two-domed teacher's house. The buildings were needed, but they also served as excellent examples.

Interest was growing in the Agadez area. Obtaining wood and mats for flat roofs was a severe problem. Mouloul's buildings were considered attractive and were demonstrating that they could resist rain. He was asked to construct a single-domed structure to serve as an artisan's cooperative shop in Azel. EIRENE donated his services. Although simple, the finished building (see photo 20a) was constructed and finished to a high standard, and attracted much favourable attention.



Photo 20a: Artisan's cooperative, Azel; built by Mouloul Amoumoun.

A Tuareg from the Tchirozérine region, Mouloul started his working life on the construction of barrages with the local Catholic mission. His first experience of house construction (in cement blocks, concrete, tin etc.) came when he joined a company building staff housing for the state mining company, SONICHAR. From there, he joined EIRENE (an NGO based in Agadez), building small rock barrages and reinforced concrete wells.

EIRENE, having heard about the construction work in Iférouane, and believing that it could meet some of their own and local building needs, decided to send Mouloul to PAT for training. For two months he worked on the construction of project buildings in Tin Telloust, where he learnt to build domes on rectangular bases.

Eventually, EIRENE no longer had need for a builder, and Mouloul was ready to strike out on his own. He broadened his experience by working on a number of PAT buildings, both as a builder and as an instructor. Since that time, demand for his skills has remained high. For the householder, his buildings have clear advantages: all his materials are available locally, instead of the arduous search for now inferior wood; lower maintenance costs and effort can be expected, as beams and/or mats no longer have to be replaced. Companies are also beginning to show an interest in these techniques: SONICHAR, the state mining company, is particularly keen, notably because of the high costs of cooling their present cement and corrugated iron buildings. For simple buildings, Mouloul is well able to carry out the work. At the present, for more complex buildings (for which there is also a demand), he needs design and technical help.

6. Climatic performance

Much has been written about the climatic comfort of unfired earth buildings with vaults and domes. In Niger, the experience of the end-users, confirmed by controlled tests carried out in 1989/90, suggests two conclusions.

Earth buildings with roofs in domes and vaults are in themselves no more nor less comfortable than houses with earth walls and flat roofs covered with earth. At the same time in winter, the temperature within them is higher than in both *pailloles* and so-called *en dur* (durable) constructions i.e. light roofs with false ceilings and walls in cement blocks. This fact is significant for the poor: one can lie down in the shade to escape heat, but it is more difficult to escape the cold and the cold season is invariably the time of sickness, particularly for the old and young.

The climatic comfort of buildings with vaults and domes depends above all on the design of the building, which - to be satisfactory - should be well-ventilated and have well-protected openings.

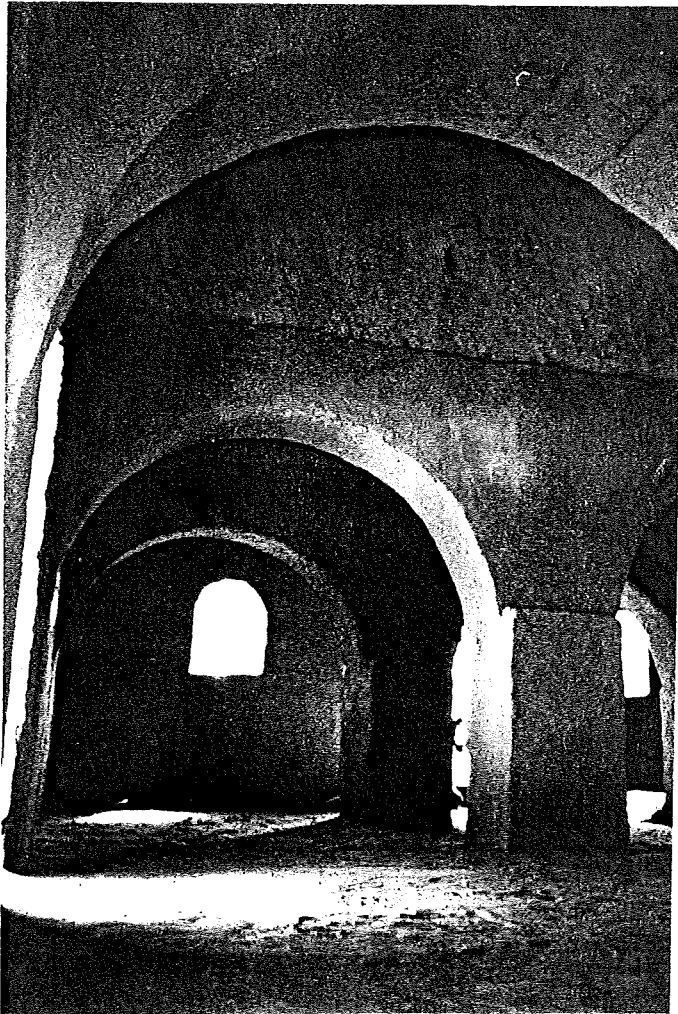

Photo 21: Well-designed orientation and ventilation for climatic comfort: interior, the mosque at Bankoukou, designed and constructed by Mal-lam Abdou, 1990. (See also photo 8.)

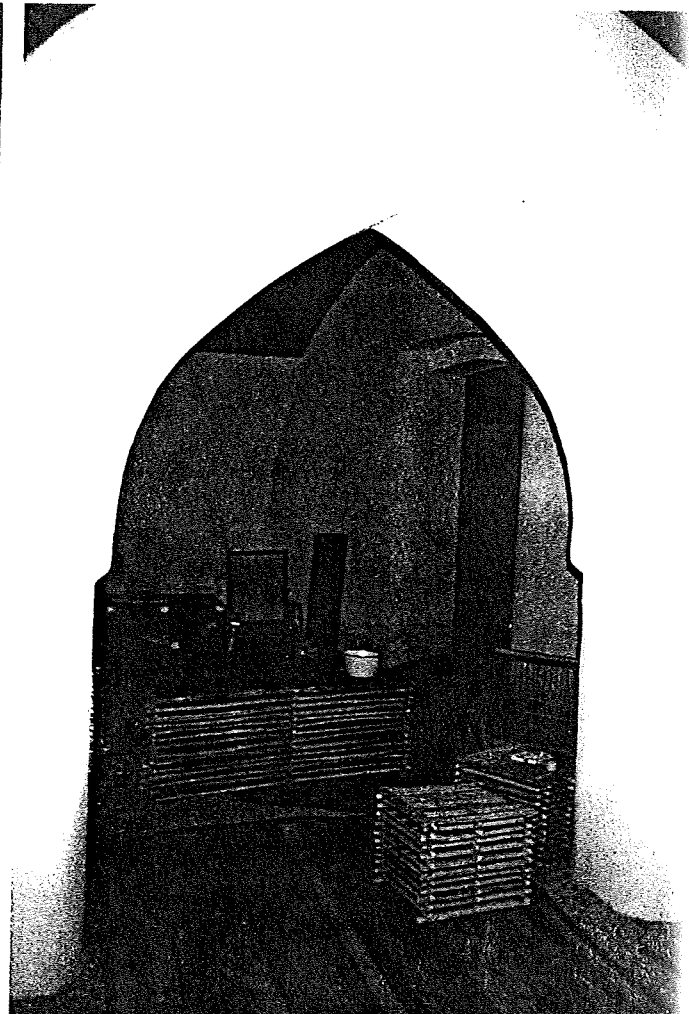

Photo 21a: A clean, dust-free living environment: interior, Villa "Louvat", Iférouane. (See also photo 19.)

7. Costs

7.1 Direct costs

We have already referred to the problems in evaluating these building techniques solely on financial grounds. Nevertheless this remains an important factor.

The real costs of three examples of two-room buildings, with comparable usable surface areas, is given in Appendix 3. These are simple buildings, (interior and exterior earth render, locally made doors and windows), built in Iférouane and Shiwil, that is to say in areas where these techniques are widespread.

The houses in question are:

House type 1a:	rectangular roomed house with flat roof using good quality wood;
House type 1b:	the same house, assuming the use of poor quality wood, and no tree-cutting permit;
House type 2:	two room house with domes (see photo 13);
House type 3:	two room house with vaults (see photo 22).

The cost per m² is as follows:

House type 1a (good wood):	9,200 Fcfa/m ²
House type 1b (poor wood):	6,400 Fcfa/m ²
House type 2, domes:	7,100 Fcfa/m ²
House type 3, vaults:	8,400 Fcfa/m ² .

To evaluate these costs correctly it must borne in mind that house type 1a shows the real cost of using good quality wood (*Hyphenae thebaica*), costly, but according to local experience likely to last between 10 and 20 years. The theoretical calculation of house type 1b assumes the use of poor quality wood (*Acaccia radiana* and *Calotropis procera*) obtained without a tree-cutting permit. The initial building cost falls sharply, but the wood will need to be replaced at least partially after between 1 and 3 years. Thus the combined cost of construction and maintenance will easily exceed that of 1a, and indeed that of house type 2.

Thus we can conclude that domed and vaulted structures are cheaper in the long term, a price differential which will continue to become more significant as wood prices rise and quality falls.

At the same time, it must be said that cost considerations alone will rarely dictate the choice between these three types of building: a client normally uses a certain builder, a member of his family or a friend with whom he has a special relationship. Only if this person can build domes and vaults do these become options. This again emphasizes the need for wide-spread training.

7.2 Indirect costs

The above analysis of the actual costs to individuals of particular buildings does not of course take into account the indirect (project-borne) costs which have made the alternative techniques available to the local population. These indirect costs include:

- the long-term provision of a technically qualified person to manage and run building programmes providing "on-the-job" training and demonstration buildings;
- the costs of running dedicated training programmes;
- shorter technical inputs to address specific issues relating to the use of the techniques
- the publication of materials intended to inform a wider public.

To try to give an indication of these costs, actual data has been provided by IUCN/WWF for the financial years April 1987 to March 1990. These are as follows:

	1/04/87 TO 31/03/88	1/04/88 TO 31/03/89	1/04/89 TO 31/03/90	1/04/87 TO 31/03/90
1. TECHNICAL ADVISER (half of cost *)	£12,200	£12,200	£12,300	£36,700
2. TRAINING ELEMENT OF PROJECT FUNDED BUILDINGS(20%)	£3,100	£3,900	£2,000	£9,000
3. CONSTRUCTION ELEMENT OF PROJECT FUNDED BUILDINGS(80%)	£12,400	£15,600	£7,800	£35,800
4. DEDICATED TRAINING PROGRAMMES	£1,500	£18,250		£19,750
5. SHORT TERM TECHNICAL ASSISTANCE INPUTS	£1,000		£11,400	£12,400
6. PUBLICATIONS			£4,500	£4,500
TOTALS	£30,200	£49,950	£38,000	£118,150
INDIRECT COSTS (ie totals less line 3)	£17,800	£34,350	£30,200	£82,350

* The construction programme absorbed approximately half of the adviser's time

During this same period 70 of the buildings constructed using vaults and domes can be attributed directly to the IUCN/WWF programme, that is they were either funded and constructed by the IUCN/WWF project itself (31 buildings), or by builders trained by the project on behalf of other clients (39 buildings). Thus a very crude calculation of additional indirect costs per building is as follows:

$$\text{indirect costs / buildings constructed} = £82,350 / 70 = £1,176 \text{ per building}$$

This represents on average approximately half as much again as direct building costs, bearing in mind that most of the buildings amongst the 70 in question are relatively large, and finished to a high standard.

The pyramid effect of more builders being trained, more buildings being constructed, and more spontaneous building taking place (as more built examples appear and more competition among builders emerges) will clearly continue to push this average additional indirect cost per building down.

8. An assessment of the demand for vaults and domes

8.1 Overview

Interest in and enthusiasm for the techniques is present and growing amongst:

- nearly all the organizations who have sent builders or technicians for training;
- villagers and village builders;
- the representatives of certain state departments, large companies and various Nigerian organizations.

All have clearly expressed their desire to have obtain training and/or to build using the techniques.

8.2 Obstacles to the further spreading of the techniques

These include inadequate knowledge and a lack of trained builders.

A number of individuals, organizations and authorities simply do not yet know about the techniques and therefore continue to build out of wood. Built examples can go a long way to rectifying this, as can public information campaigns reaching a wider public.

The lack of trained builders has already been referred to above. In Iférouane alone, there is currently a "waiting list" for private buildings, and one Iférouane builder reports that he has received requests for building from Arlit, Agadez and Tahaoua which he and his team of builders are at present unable to meet.

8.3 Public sector demand

Despite recent encouraging developments, this remains low. The authorities would like to see built examples in each region in order to have a better grasp of the cost and viability of the buildings. Following this the problem of having enough technicians and site supervisors to design and manage constructions will need to be addressed. Training is required to rectify this latter problem.

8.4 Popular demand

Although difficult to assess this will clearly be the key in the long term.

At present it is linked to the presence of built examples in a given area and of trained builders. A clear demand has been noted in and around Iférouane, Tchirozérine, Azel, Chikal and Ichiguiné (Niger) and around Ménaka (Mali). Here, demand has outstripped the capacity to build.

Elsewhere, for example in Azel (10kms from Agadez) which has three domed "reference" buildings, there are no trained builders in the village, but the women

(who traditionally assume the responsibility for building *paillotes*), increasingly discouraged by termite problems and the lack of organic materials, have stated their readiness to transport bricks to make the "new" buildings, as they did for the three domed structures. Training aimed at women could therefore also make an important contribution, and could focus on the a basic round domed structure with 20cm walls.

In general, the people and the builders are alive to the fact that although the initial building costs of vaults and domes may be slightly higher than for wooden roofed structures, they also last longer. As the cost of wood rises, even the short term comparison will favour the adoption of the new techniques.

8.5 Organizational and private demand

A detailed questionnaire used in the course of the May/June 1990 survey established that numerous NGOs and similar organizations, as well as builders and state bodies, are clearly interested in and committed to the techniques.

The answers given in response to the questionnaire are summarized in Appendix 4.

8.6 Perceived problems

Certain fears remain despite the local success of the buildings.

The first of these concerns the ability of the structures to resist rain. This is fundamental to the viability of the techniques and can be evaluated thanks to the performance of existing buildings. Amongst these, some built ten years ago in areas of high rainfall (350mm/year) have demonstrated that without the use of cement-based renders and with little maintenance, the buildings resist rain damage well. (This does not mean that the buildings would resist rain in any region with any material: caution is needed and is taught.)

A fundamental factor, however, is the quality of the render used, (good earth, well prepared) and the design of the building allowing rapid run-off of rain water from roofs and away from foundations. Even if these conditions are met, however, regular inspection and maintenance is indispensable. As the latter occurs gradually, however, it never represents a major expense.

The second perceived problem relates to the costs of vaults and domes built in unstabilized sun-dried bricks. This is due to a misunderstanding, common amongst funders and donors, as well as potential end-users. The techniques in question, that is for buildings with vaults and domes, are sometimes confused with apparently similar buildings examples of which are widespread in the Sahel. There is, however, a key difference: we are concerned here with buildings using unbaked unstabilized earth, whereas many of the better known examples are in stabilized or fired earth bricks. The cost of these buildings is at least equal to that of buildings made of cement blocks and corrugated iron roofs, and therefore prohibitive for public buildings, much less for the population at large. Moreover the skills and the notion of quality control to use these "modern" materials are absent.

This confusion has resulted in some instances in a false idea of the cost and technical viability of the buildings in unstabilized earth blocks.

Finally, local trained builders sometimes tend to favour the round buildings, which are stronger and easier to construct. This has led some people who prefer rectangular buildings to discount woodless construction, believing that it cannot meet their requirements for rectangular or square buildings. If each region had a complete range of buildings - round domed, square domed and square or rectangular vaulted buildings - this misconception could be rectified.



Photo 22: Two-room house with vaults; see page 32, House type 3, for actual costs of this building.

9. Towards the future

From the review of the current situation outlined above, it is clear that there is a need for

- training;
- informing a wider public at all levels;
- a post-training service for technical assistance and quality control.

Hence the current initiative to put into place a specialized training and information unit, located in Agadez, which could assume this role and which could be handed over to Nigerian staff in the near future. A mission to set up the institutional aspects of this organization in January 1991 was successful in obtaining the support of the relevant ministries and a piece of land has been donated by the local authority in Agadez. Funds are now being sought for the setting-up and initial running of the Unit (see separate project proposal document).

10. Conclusions

It is suggested that the introduction to Niger (and a part of N.E. Mali) of the Nubian system of vault and dome construction in unstabilized sun-dried earth bricks described above has made a contribution in the following areas:

- *provision of low-cost housing for the poorest section of the community*

The techniques in question are flexible enough to be within reach of the poorest sections of the community, as well as adapted to more sophisticated facilities and homes. Indeed as wood becomes still scarcer and more expensive, the techniques can resolve many of the problems of building with wood, problems to which the poor are most vulnerable.

- *sustainable lifestyle in rural areas*

The overall environmental context in which the techniques were first introduced and have flourished - i.e. desertification, the degradation of the environment, and increasing sedentarisation on the part of previously nomadic people - makes clear their contribution to sustainable lifestyle in rural areas.

- *energy efficient housing*

Earth's large thermal mass value make its use particularly appropriate in areas of wide diurnal temperature range. This gives year round benefit, but is particularly important in the cold season, where these buildings perform better than those built with "modern" materials.

- *unemployment*

The fact that the techniques use only a local material - earth - and local labour is particularly relevant in a country which must import all "modern" materials and has much under-utilized labour.

- *diminishing natural resources*

The techniques directly address the extreme scarcity and in some cases disappearance of certain species of wood.

- *sustainable future*

The future of a huge part of the Sahel and of the southern Sahara is in jeopardy. Woodless construction has a contribution to make in addressing successfully the problem of building with wood, which is both one of the symptoms and the causes of the underlying problem of desertification.

It is also suggested that:

- *the construction techniques in question are replicable*

in other countries of the Sahel facing the same problems of increasing desertification and scarcity of traditionally used wood, and that

- *the approach used for its introduction is replicable*

in any area facing the need to modify its traditional building practises as a result of a fast-changing environment.

2. Plan, sections and elevation

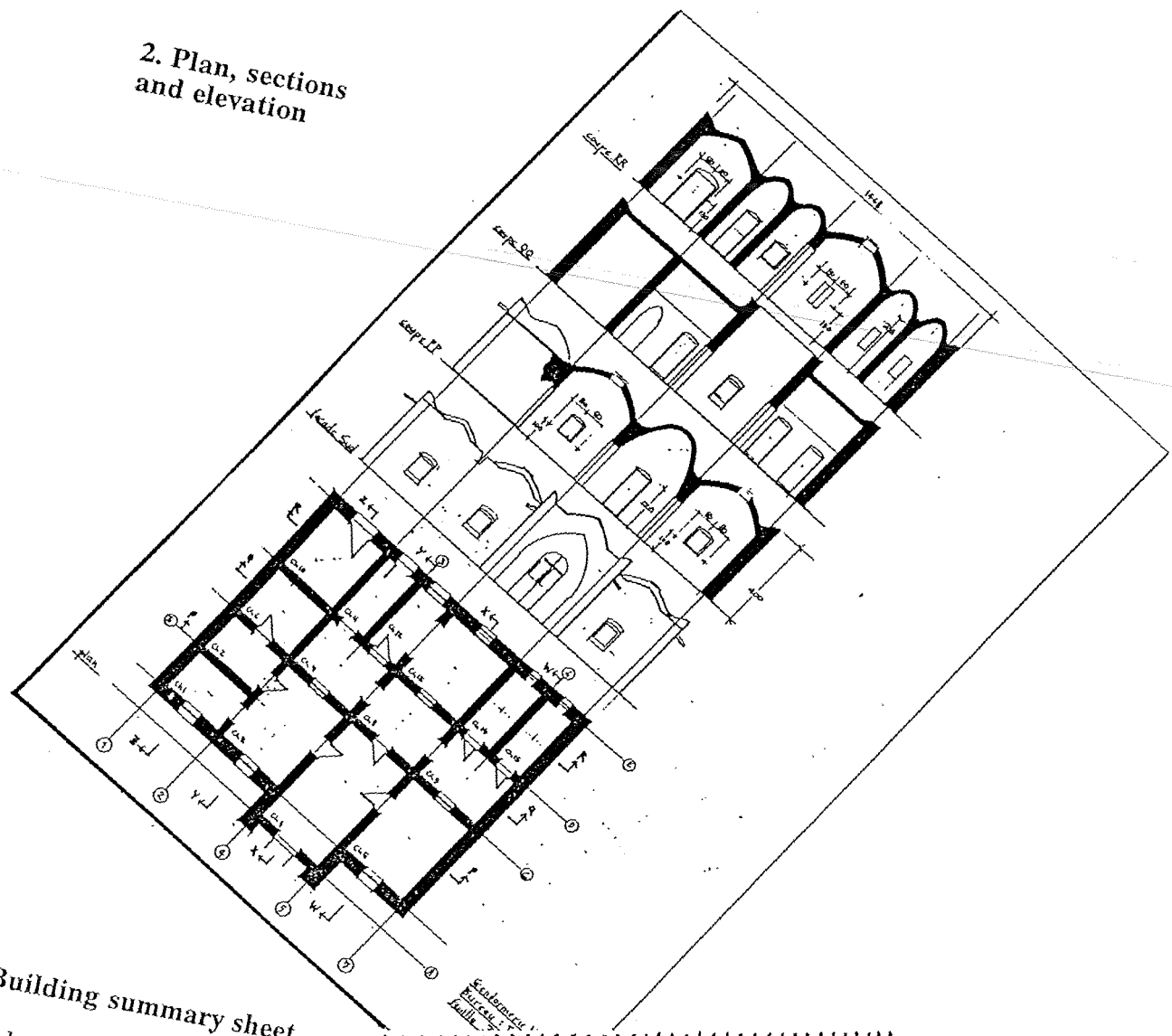

3. Building summary sheet

Used together with the plan, allows the construction of the basic structure.

Bureau Gendarmerie Nationale Iferouane

Ch	Fonction	Toit	h	d	p	Remarques
1	radio	C	190	50		
2	mag munitions	C	190	50		
3	bureau gendarmes	C	100	80		
4	cellule publique	V	220		212	encadre en fer (brique) dans les murs sur les portes
5	bureau adjoint CB	G	60	80		
6	magasin armes	V	252		224	les (14) supports sur les murs en fer
7	couloir salle d'attente	V			224	
8	patio ouvert	ouvert				
9	couloir	V	252		214	
10	magasin	C	130	80		
11	couloir	V	258		136	
12	bureau CB	V	258		136	les (14) supports en fer
13	bureau CB	C	150	80	80	
14	cellule	V	258		136	
15	cellule	V	258		136	

Voute 'V'

Couloir 'C'

Appendix 2

List of buildings built in Niger and Mali using the Nubian system of vault and dome roofing

[Data collected by Development Workshop in the course of a survey carried out May/June 1990 on behalf of IUCN.]

Abbreviations: -

ROOMS

SD Dome on square base
RD Dome on round base
V Vault

FINANCING

PROJ Project
ST State
EXT External client
PRIV Private, owner-occupied i.e."spontaneous"

BUILDING(S)	N ^O OF BUILDINGS	PLACE	YEAR	ROOMS			FINANCING			
				SD	RD	V	PROJ'	ST	EXT'	PRIV'
CHIKAL REGION										
STRUCTURE DE DEMONSTRATION	1	CHIKAL	80	1	1		1			
CENTRE D'ALPHABETISATION	1	CHIKAL	80	3	1		1			
STATION METEO	1	CHIKAL	81	5	4			1		
ABRI POULETS	1	CHIKAL	81		1		1			
ABRI OUTILS	1	CHIKAL	81		1		1			
MAISON ALASSAN	1	CHIKAL	82		2					1
ABRI GENERATOR	1	CHIKAL	82		1		1			
MAISON PASSAGE PTV	1	CHIKAL	83	2	2		1			
CASE MALADES	1	CHIKAL	83		1		1			
BATIMENT DEMO N ^O 1	1	FILINGUE	83		2			1		
BATIMENT DEMO N ^O 2	1	FILINGUE	83		2			1		
MAISON SAIDOU BOUBAKER	1	TOUNFALIZ	83	2	1					1
MAISON NPP	1	SHIWIL	83		2				1	
MAISON SNV N ^O 1	1	BALEYARA	83	3	3				1	
BUREAU PTV	1	CHIKAL	84	4	4		1			
CENTRE NPP	5	ITCHEGIN	84		10				5	
CENTRE NPP	5	KONI BERI	84		10				5	
CENTRE NPP	5	KABE	84		10				5	
MAISON NPP	1	ITCHEGIN	83		2				1	
MAISON M. ADDA	1	CHIKAL	85		2					1
MAISON M AKORA	1	CHIKAL	86	2						1
BOUTIQUE MAIYAKI	1	CHIKAL	90	1						1
BATIMENTS DE FORMATION	2	CHIKAL	90	2	2		2			
MAISON NPP	1	ITCHEGIN	83		2				1	
MAISON M ABDOU	1	ITCHEGIN	83		4					1
ZAURE M ABDOU	1	ITCHEGIN	84	1						1
MOSQUEE	1	ITCHEGIN	87	1						1
CASE PASSAGE	1	ITCHEGIN	87	1						1
MAISON PRIVE	1	ITCHEGIN	88	4						1
CASE LOGEMENT	1	CHAT	89	1						1
MAISON AMADOU MA-ASADI	1	KWARE	90	2						1
MOSQUEE	1	BANKOUKOU	90		4					1
TOTAL	45			35	0	74	10	3	19	13

contd. over

Appendix 2, contd.

BUILDING(S)	N ^o OF BUILDINGS	PLACE	YEAR	ROOMS			FINANCING			
				SD	RD	V	PROJ'	ST	EXT'	PRIV'
IFEROUANE REGION										
MAISON TSHOHO HAMO	1	IFEROUANE	88	1						1
MAISON AGARABA	1	IFEROUANE	87		1		1			
VILLA III PCGRNAT	1	IFEROUANE	88		8		1			
CASE VILLA III	1	IFEROUANE	88		1		1			
VILLA II PCGRNAT	1	IFEROUANE	88		7		1			
VILLA I PCGRNAT	1	IFEROUANE	88	6			1			
CUISINE VILLA I	1	IFEROUANE	88	2		1	1			
CASE DE PASSAGE VILLA I	1	IFEROUANE	89		1		1			
CASE DE PASSAGE	1	IFEROUANE	89	1			1			
CASE DE PASSAGE	1	IFEROUANE	89		1		1			
CASE DE PASSAGE	1	IFEROUANE	89			1	1			
BUREAU PCGRNAT	1	IFEROUANE	85	4		4	1			
GARAGE PCGRNAT	1	IFEROUANE	85	4			1			
GARDIEN PCGRNAT	1	IFEROUANE	85	1			1			
MAGASIN PCGRNAT	1	IFEROUANE	88			3	1			
BUREAU ORDINATEURS PCGRNAT	1	IFEROUANE	89			2	1			
CASE GARDIEN PCGRNAT	1	IFEROUANE	88		1		1			
CASE GROUPE PCGRNAT	1	IFEROUANE	87				1			
BUREAU GENDARMERIE	1	IFEROUANE	89	6		8		1		
VILLA CHEF DE BRIGADE	1	IFEROUANE	89		6			1		
-CASE RONDE	1	IFEROUANE	89		1			1		
VILLA ADJ CHEF DE BRIGADE	1	IFEROUANE	89		5			1		
-CASE RONDE	1	IFEROUANE	89		1				1	
MAISON DJEHOUTA	1	IFEROUANE	90		1			1		
DISPENSAIRE	1	IFEROUANE	89			3	1			
FOUR	1	IFEROUANE	85		1		1			
MAISON YOUSOUFOU	1	IFEROUANE	88		1					1
CASE RONDE DE TAAMANA	1	IFEROUANE	88		1					1
CENTRE TOURISTIQUE	1	IFEROUANE	90	6		2	1			
ARTISANAT	1	IFEROUANE	90	6			1			
CUISINE ECOLE	1	IFEROUANE	88		1		1			
SALLE DE REUNION, CVD	1	IFEROUANE	88		3		1			
MAISON AHMED MAZAWAJE	1	IFEROUANE	UC	2						1
MAISON ELHAJI MAZAWAJE	1	IFEROUANE	88	2						1
MAISON MOUSSA AMGAR	1	IFEROUANE	86	2		1				1
CASES M. AMGAR	1	IFEROUANE	87	2						1
MAISON HAMIDAN AMGAR	1	IFEROUANE	UC	2						1
MOUSSA AMGAR	1	IFEROUANE	UC	3						1
CASE TITI SALAH	1	IFEROUANE	90		1		1			
MAISON TOUMA LOUVAT	1	IFEROUANE	89		8					1
MAISON MHMD. ILYAS	1	IFEROUANE	89			2	.50			.50
MAISON IBRAHIM ILYAS	1	IFEROUANE	89	1			.50			.50
MAISON MOUSA AKHMED	1	IFEROUANE	88		2					1
MAISON HAMOKHA	1	IFEROUANE	90		2					1
CASE TINIJIRA	1	IFEROUANE	89		1		1			
CASE HABSOU	1	IFEROUANE	89		1		1			
CASE TAMINAKITT	1	IFEROUANE	89		1		1			
CASE BATOURÉ	1	IFEROUANE	88		1		1			
CAMPMENT K.MHMD.	4	IFEROUANE	90	8						4
CASE SADEK WOURO	1	IFEROUANE	88							1
MAISON BIRGI RAFINI	1	IFEROUANE	88							1
BUREAU PCGRNAT	2	TIN TELLOUST	86				2			
LGMNT. FORESTIER	3	TIN TELLOUST	89				3			
LGMNT. CHAUFFEUR	2	TIN TELLOUST	89		4		2			
TOTAL	61			54	67	27	37	5	0	19

Appendix 2, contd.

BUILDING(S)	N ⁰ OF BUILDINGS	PLACE	YEAR	ROOMS			FINANCING			
				SD	RD	V	PROJ'	ST	EXT'	PRIV'
TCHIROZERENE REGION										
CASE EIRENE	1	TAFADEK	87				1			
CASE EIRENE	1	TIN TABIZGIN	86	3			1			
COOPERATIVE	1	AZEL	87	1				1		
CASE PETITE SOEURS	1	AZEL	89		1					1
MAGASIN DE VENTE	1	AZEL	89		1			1		
MAISON MOULOUL	1	TCHIROZERENE	90	2						1
CASE AGAK ALGHAGHAS	1	TCHIROZERENE	90		1					1
LOGEMENT SOEURS	1	TCHIROZERENE	90	5		10				1
CASE PROFESSEUR	1	TCHIROZERENE	90	1			1			
CUISINE BAKARI	1	TCHIROZERENE	90	1						1
CASE BILA AKENOU	1	TCHIROZERENE	90		1					1
TOTAL	11			13	4	10	3	0	2	6
MENAKA REGION (MALI)										
C.R.E.N.	3	MENAKA			3		3			
THEATRE	1	MENAKA		4		4	1			
- CASES DE PASSAGE	10	MENAKA			10		10			
DOMES DES OASIS	70	MEN' REGION			70		70			
BATIMENTS SPONTANES	21	MEN' REGION		21		21				21
BUREAU PREFET	1	MENAKA	90		3		1			
C.R.E.N.	3	ANDARAMBOUKANE			3		3			
THEATRE	1	ANDARAMBOUKANE		4		1	1			
CUISINE ECOLE	1	ANDARAMBOUKANE	90			2			1	
CASES CO-OP	2	ANDARAMBOUKANE			2		2			
MAISON DE M. MENENA	1	ANDARAMBOUKANE			3		1			
MAISON PRIVE	1	ANOZAGARENE		2						1
ECOLE	1	ANOZAGARENE	89	2			1			
TOTAL	116			33	94	28	93	0	1	22
VARIOUS REGIONS										
MAISON KAMAI	1	NIAMEY	83	2		1				1
BUREAU SIM	1	DANJA (MARADI)	86	7				1		
LOGEMENT SIM	1	DANJA (MARADI)	86			2		1		
MAISON SERAFINI	1	RIO BRAVO	86	3		1				1
MAISON SNV N ⁰ 2	1	BALEYARA	87	3		5		1		
GARAGE	1	DOGON DOUTCHI	88	2		2		1		
SALIN: - VILLAS	5	TIDDIKELT	89	15		15		5		
- CASES OUVRIERS	38	TIDDIKELT	89	-		-		38		
MAISON VCP	1	QUALLAM	89		2			1		
GARAGE/MAISON	1	DOSSO	88	1		3		1		
ARTISANAT	3	DOSSO	90		7		3			
CASE RONDE (KRUGER)	1	ZINDER	89		1		1			
CASE RONDE (KRUGER)	1	ZINDER	89		1		1			
MAISON PIET	2	TIMIA	88	4		4				2
MAGASIN	1	TIMIA	88				1			
GARAGE GENIE RURAL	1	AGADEZ	88			2	1			
CASE GENIE RURAL	1	AGADEZ			1		1			
URC ARTISANAT(MAG'DE VENTE)	1	AGADEZ	88					1		
URC ARTISANAT(MAG'DE STOK')	1	AGADEZ	88					1		
CASE URC	1	AGADEZ	88					1		
EXTENSION ARTISANAT	1	AGADEZ	90			1		1		
BATIMENT DE COOPERATIVE	1	TAMAZALAK	89	4			1			
CASE HARUNA MAIKANO	1	TAMAZALAK	89							1
CASE PROJET BELGE	1	DOSSO	90		1		1			
CASE SAUKA LAFIYA N ⁰ 1	1	NIAMEY	83	1		1	1			
CASE SAUKA LAFIYA N ⁰ 2	1	NIAMEY	83	2		2	1			
CASE SAUKA LAFIYA N ⁰ 3	1	NIAMEY	83			1	1			
CASE PGRN	3	TCHIN TABARADEN	UC		3		3			
TOTAL	74			44	16	40	16	0	53	5
GRAND TOTAL	307			179	181	179	159	8	75	65

Appendix 3

Comparative costs of 3 building types

House type 1a: two rooms (useable floor area - 28m²)

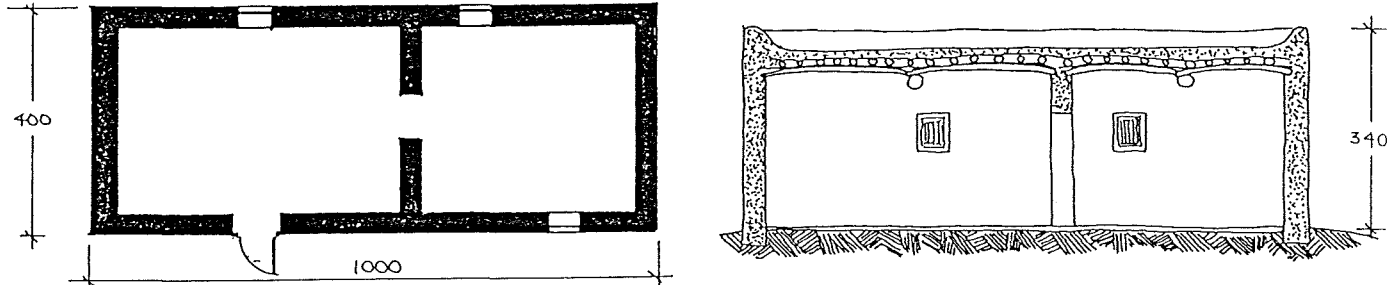

MATERIALS AND LABOUR	UNIT	QUANTITY	PRICE/ UNIT	AMOUNT	PRICE/ M ² FLOOR AREA	NOTES
NON ORGANIC MATERIALS						
BRICKS (40x20x15):						
- FOUNDATIONS 3 COURSES	BRICK	390	25	9750		
- WALLS 17 COURSES	BRICK	2210	25	55250		
- PARAPET 2 COURSE	BRICK	130	25	3250		
BRICKS (20x15x6)	BRICK	-				
EARTH FOR MORTAR AND PLASTER				0		INCLUDED IN LABOUR COSTS
WATER FOR CONSTRUCTION	BARREL	30	250	7500		
WATER FOR MIXING PLASTER	BARREL	6	250	1500		
SAND						TRANSPORTED FREE BY WIVES
DOORS	UNIT	1	4000	4000		
WINDOWS	UNIT	3	2000	6000		
SPOUTS	UNIT	3	250	750		
CEMENT	BAG	1	3500	3500		
S. TOTAL				91500	3268	
% OF TOTAL				36%		
ORGANIC MATERIALS						
WOOD;						
- LINTELS x 5	LATHS	6	250	1500		-HYPHANAE THEBAICA, DIFFICULT TO FIND
- BEAMS	UNIT	2	5000	10000		-HYPHANAE THEBAICA, DIFFICULT TO FIND
- LATHS	UNIT	68	250	17000		-HYPHANAE THEBAICA, DIFFICULT TO FIND
CUTTING PERMIT		2	12000	24000		-OFTEN NOT RESPECTED
TWO COURSES OF MATS	MAT	2	5000	10000		-TWO COURSES OF MATS INSULATE WELL AND RESIST THE SPREAD OF TERMITES
	MAT	11	1500	16500		
COURSE OF STICKS	BUNDLE	3	250	750		
TRANSPORT AND LABOUR	TRIP	1	15500	15500		
S. TOTAL				95250	3402	
% OF TOTAL				37%		
LABOUR						
CONSTRUCTION:						
- MASONS	DAY	15	1750	26250		
- LABOURERS	DAY	45	800	36000		
				0		
OUTSIDE PLASTER				0		
- MASONS	DAY	2	1750	3500		
- LABOURERS	DAY	6	800	4800		
S. TOTAL				70550	2520	
% OF TOTAL				27%		
TOTAL				257300	9189	

Appendix 3, contd.

House type 1b: two rooms (useable floor area - 28m²)

theoretical calculation, assuming house type 1a built using poor quality wood

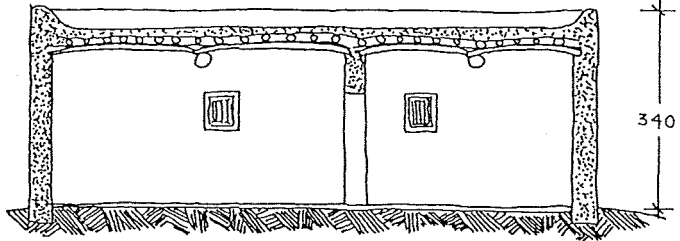
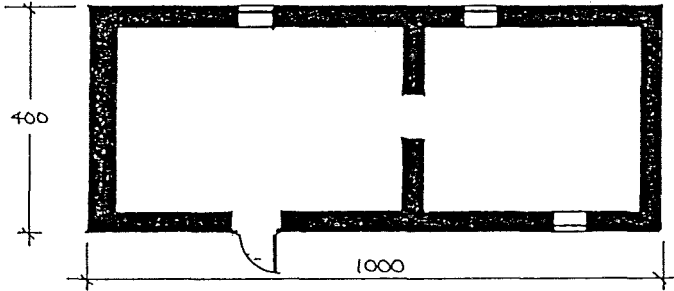

MATERIALS AND LABOUR	UNIT	QUANTITY	PRICE/ UNIT	AMOUNT	PRICE/ M ² FLOOR AREA	NOTES
NON ORGANIC MATERIALS						
BRICKS (40x20x15):						
- FOUNDATIONS 3 COURSES	BRICK	390	25	9750		
- WALLS 17 COURSES	BRICK	2210	25	55250		
- PARAPET 2 COURSE	BRICK	130	25	3250		
BRICKS (20x15x6)	BRICK	-				
EARTH FOR MORTAR AND PLASTER				0		INCLUDED IN LABOUR COSTS
WATER FOR CONSTRUCTION	BARREL	30	250	7500		
WATER FOR MIXING PLASTER	BARREL	6	250	1500		TRANSPORTED FREE BY WIVES
SAND						
DOORS	UNIT	1	4000	4000		
WINDOWS	UNIT	3	2000	6000		
SPOUTS	UNIT	3	250	750		
CEMENT	BAG	1	3500	3500		
S.TOTAL				91500	3268	
% OF TOTAL				50%		
ORGANIC MATERIALS						
WOOD;						
- LINTELS x 5	LATHS	12	50	600		-CALATROPIS PROCERA, NOT STRONG
- BEAMS	UNIT	2	1000	2000		-ACCACIA RADDIANA, SHORT LIFE SPAN
- LATHS	UNIT	68	50	3400		-CALATROPIS PROCERA, NOT STRONG
CUTTING PERMIT		0		0		-NOT RESPECTED
COURSE OF MATS	MAT	1	5000	5000		-ONE COURSE OF MATS POOR INSULATION AND
	MAT	5	1500	7500		POOR RESISTANCE TO TERMITES
COURSE OF STICKS	BUNDLE	0		0		
TRANSPORT AND LABOUR	TRIP	1	3000	3000		-AVAILABLE RELATIVELY LOCALLY
S.TOTAL				21500	768	
% OF TOTAL				12%		
LABOUR						
CONSTRUCTION:						
- MASONS	DAY	15	1750	26250		
- LABOURERS	DAY	45	800	36000		
				0		
OUTSIDE PLASTER				0		
- MASONS	DAY	2	1750	3500		
- LABOURERS	DAY	6	800	4800		
S.TOTAL				70550	2520	
% OF TOTAL				38%		
TOTAL				183550	6555	

Appendix 3, contd.

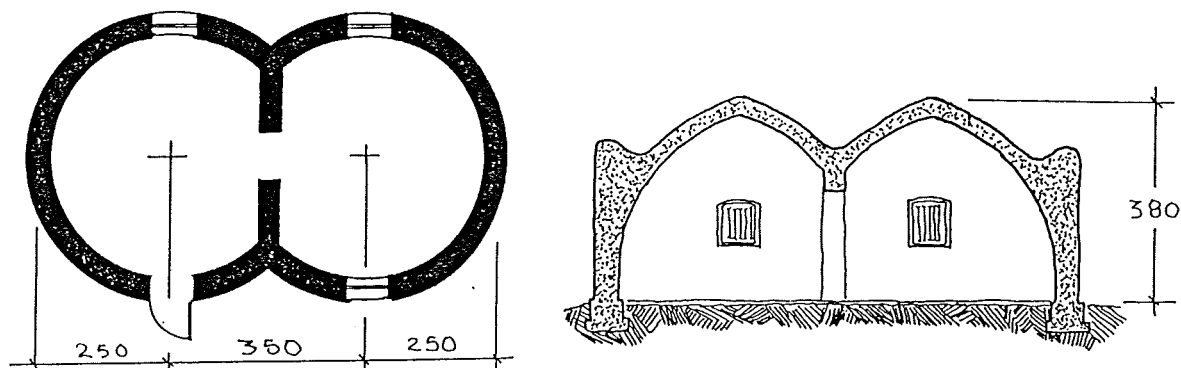
House type 2: two circular rooms (usable floor area - 30m²) - domed roof

MATERIALS AND LABOUR	UNIT	QUANTITY	PRICE/ UNIT	AMOUNT	PRICE/ M ² FLOOR AREA	NOTES
NON ORGANIC MATERIALS						
BRICKS (40x20x15):						
- FOUNDATIONS 3 COURSES	BRICK	714	25.0	17850		
- WALLS 17 COURSES	BRICK	2058	25.0	51450		
- PARAPET 2 COURSE	BRICK	130	25.0	3250		
BRICKS (20x15x6)	BRICK	4900	7.5	36750		
EARTH FOR MORTAR AND PLASTER	M ³			0		INCLUDED IN LABOUR COSTS
WATER FOR CONSTRUCTION	BARREL	35	250.0	8750		
WATER FOR MIXING PLASTER	BARREL	9	250.0	2250		
SAND						TRANSPORTED FREE BY WIVES
DOORS	UNIT	1	4000.0	4000		
WINDOWS	UNIT	3	2000.0	6000		
SPOUTS	UNIT	3	250.0	750		
CEMENT	BAG	1	3500.0	3500		
S. TOTAL				134550	4485	
% OF TOTAL				62%		
ORGANIC MATERIALS						
WOOD;						
- LINTELS x 5	LATHS	0		0		
- BEAMS	UNIT	0		0		
- LATHS	UNIT	0		0		
CUTTING PERMIT		0		0		
COURSE OF MATS	MAT	0		0		
	MAT	0		0		
COURSE OF STICKS	BUNDLE	0		0		
TRANSPORT AND LABOUR	TRIP	0		0		
S. TOTAL				0	0	
% OF TOTAL				0%		
LABOUR						
CONSTRUCTION WALLS:						
- MASONS	DAY	13	1750.0	22750		
- LABOURERS	DAY	37	800.0	29600		
CONSTRUCTION DOMES:						
- MASONS	DAY	5	1750.0	8750		
- LABOURERS	DAY	15	800.0	12000		
OUTSIDE PLASTER				0		
- MASONS	DAY	3	1750.0	5250		
- LABOURERS	DAY	6	800.0	4800		
S. TOTAL				83150	2772	
% OF TOTAL				38%		
TOTAL				217700	7257	

Appendix 3, contd.

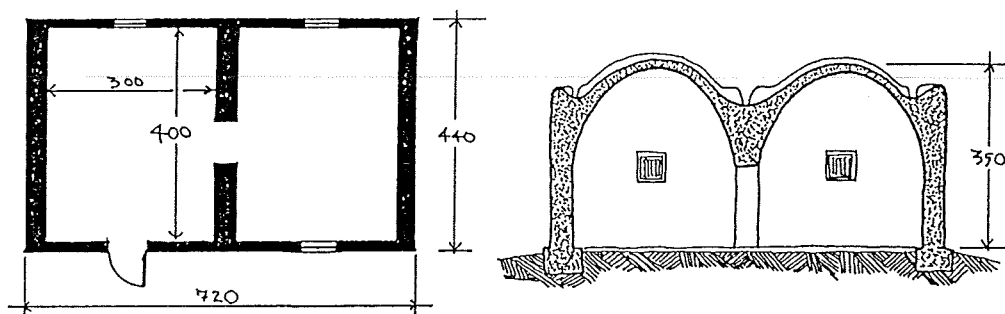
House type 3: two rectangular rooms (usable floor area - 24m²) - vaulted roof

MATERIALS AND LABOUR	UNIT	QUANTITY	PRICE/ UNIT	AMOUNT	PRICE/ M ² FLOOR AREA	NOTES
NON ORGANIC MATERIALS						
BRICKS (40x20x15):						
- FOUNDATIONS 3 COURSES	BRICK	450	25.0	11250		
- WALLS	BRICK	1500	25.0	37500		
- PARAPET 2 COURSE	BRICK	40	25.0	1000		
BRICKS (20x15x6)	BRICK	3000	7.5	22500		
EARTH FOR MORTAR AND PLASTER	M ³			0		INCLUDED IN LABOUR COSTS
WATER FOR CONSTRUCTION	BARREL	28	250.0	7000		
WATER FOR MIXING PLASTER	BARREL	5	250.0	1250		
SAND						TRANSPORTED FREE BY WIVES
DOORS	UNIT	1	4000.0	4000		
WINDOWS	UNIT	3	2000.0	6000		
SPOUTS	UNIT	3	250.0	750		
CEMENT	BAG	1	3500.0	3500		
S.TOTAL				94750	3948	
% OF TOTAL				47%		
ORGANIC MATERIALS						
WOOD;						
- LINTELS x 5	LATHS	0		0		
- BEAMS	UNIT	0		0		
- LATHS	UNIT	0		0		
CUTTING PERMIT		0		0		
COURSE OF MATS	MAT	0		0		
	MAT	0		0		
COURSE OF STICKS	BUNDLE	0		0		
TRANSPORT AND LABOUR	TRIP	0		0		
S.TOTAL				0	0	
% OF TOTAL				0%		
LABOUR						
CONSTRUCTION WALLS:						
- MASONS	DAY	9	1750.0	15750		
- LABOURERS	DAY	36	800.0	28800		
CONSTRUCTION VAULTS:						
- MASONS	DAY	12	1750.0	21000		
- LABOURERS	DAY	36	800.0	28800		
OUTSIDE PLASTER						
				0		
- MASONS	DAY	3	1750.0	5250		
- LABOURERS	DAY	9	800.0	7200		
S.TOTAL				106800	4450	
% OF TOTAL				53%		
TOTAL				201550	8398	

Appendix 4

Summary of interest in Nubian vault and dome technology

[Results taken from answers to questionnaire used by Development Workshop in the course of a survey carried out May/June 1990 on behalf of IUCN.]

ORGANISATION OR GROUP	SUPPORT THE POPULARISATION OF V & D	HAVE PREVIOUSLY USED V & D	CONTINUE USING V & D	RUN TRAINING COURSES IN V & D	REQUIRE TRAINING IN V & D	PLAN TO CONSTRUCT USING V & D	WOULD APPRECIATE TECHNICAL ASSISTANCE	HAVE INTERESTED PERSONNEL	NEED LOCALLY PROVEN EXAMPLES
N.G.O.s									
VISION MONDIALE/ MALI	■■■	■■■	■■■	■■■	■■■	■■■	■■■	■■■	
B.I.T/ NIAMEY, DOSSO	■■■	■■■	■■■	■■■	■■■		■■■	■■■	
KRUGER/ NIAMEY, ZINDER	■■■	■■■			■■■		■■■	■■■	
PETITES SOEURS/ AZEL	■■■	■■■					■■■	■■■	
MISSION CATHOLIQUE/ TCHIRO	■■■	■■■	■■■				■■■	■■■	
P.G.R.N./ TIN TABARADEN	■■■	■■■	■■■		■■■	■■■	■■■	■■■	
CORPS DE LA PAIX	■■■	■■■	■■■		■■■	■■■	■■■	■■■	
U.R.C./ AGADEZ	■■■	■■■				■■■	■■■	■■■	
WWF/IUCN-PCGRNAT	■■■	■■■	■■■	■■■	■■■	■■■	■■■	■■■	
S.I.M./ DANJA (MARADI)		■■■			■■■	■■■	■■■	■■■	■■■
SONICHAR/ TCHIRO'	■■■				■■■	■■■	■■■	■■■	
PTV/ CHIKAL	■■■	■■■	■■■	■■■	■■■		■■■	■■■	
C.A.R.E./ MARADI								■■■	■■■
E.I.R.E.N.E./ AGADEZ	■■■	■■■						■■■	
O.N.V.P.E.	■■■				■■■	■■■	■■■	■■■	
A.N.V.	■■■							■■■	
I.S.A.I.D.	■■■	■■■			■■■	■■■	■■■	■■■	
ASSOCIATION TAMAZALAK	■■■	■■■			■■■	■■■	■■■	■■■	
BUILDERS									
Macons de ICHIGUINE	■■■	■■■	■■■	■■■	■■■	■■■	■■■	■■■	
Macons de TCHIROZERENE	■■■	■■■	■■■	■■■	■■■	■■■	■■■	■■■	
Macons de IFEROUANE	■■■	■■■	■■■	■■■	■■■	■■■	■■■	■■■	
Macons de CHIKAL	■■■	■■■	■■■		■■■	■■■	■■■	■■■	
Macons d'AGADEZ	■■■	■■■	■■■		■■■	■■■	■■■	■■■	
Macons de MENAKA	■■■	■■■	■■■			■■■	■■■	■■■	
Macons de DOSSO	■■■	■■■	■■■			■■■	■■■	■■■	
Macons de TAMAZALAK	■■■	■■■				■■■	■■■	■■■	
STATE									
D.F.P.P./NIAMEY	■■■								■■■
EQUIPEMENT/NIAMEY	■■■	■■■					■■■	■■■	■■■
PRESIDENT C.N.D./NIAMEY	■■■	■■■				■■■		■■■	
GENDARMARIE NATIONALE	■■■	■■■			■■■	■■■		■■■	
S.G.A./AGADEZ	■■■					■■■		■■■	
MAIRE/AGADEZ						■■■			
DIR' DE L'ENVIRONNEMENT/AG	■■■					■■■	■■■	■■■	
EQUIPEMENT/AGADEZ	■■■					■■■		■■■	
GENIE RURAL/AGADEZ	■■■	■■■				■■■	■■■	■■■	

Appendix 5

3 basic housing structures which can be used either free-standing, or in combination for more complex buildings.

These three basic structures were used to illustrate the building process in the manual "Les toitures sans bois" ("Woodless roof construction") a copy of which is appended in the Annex material.

Dome on rectangular base - plan and section

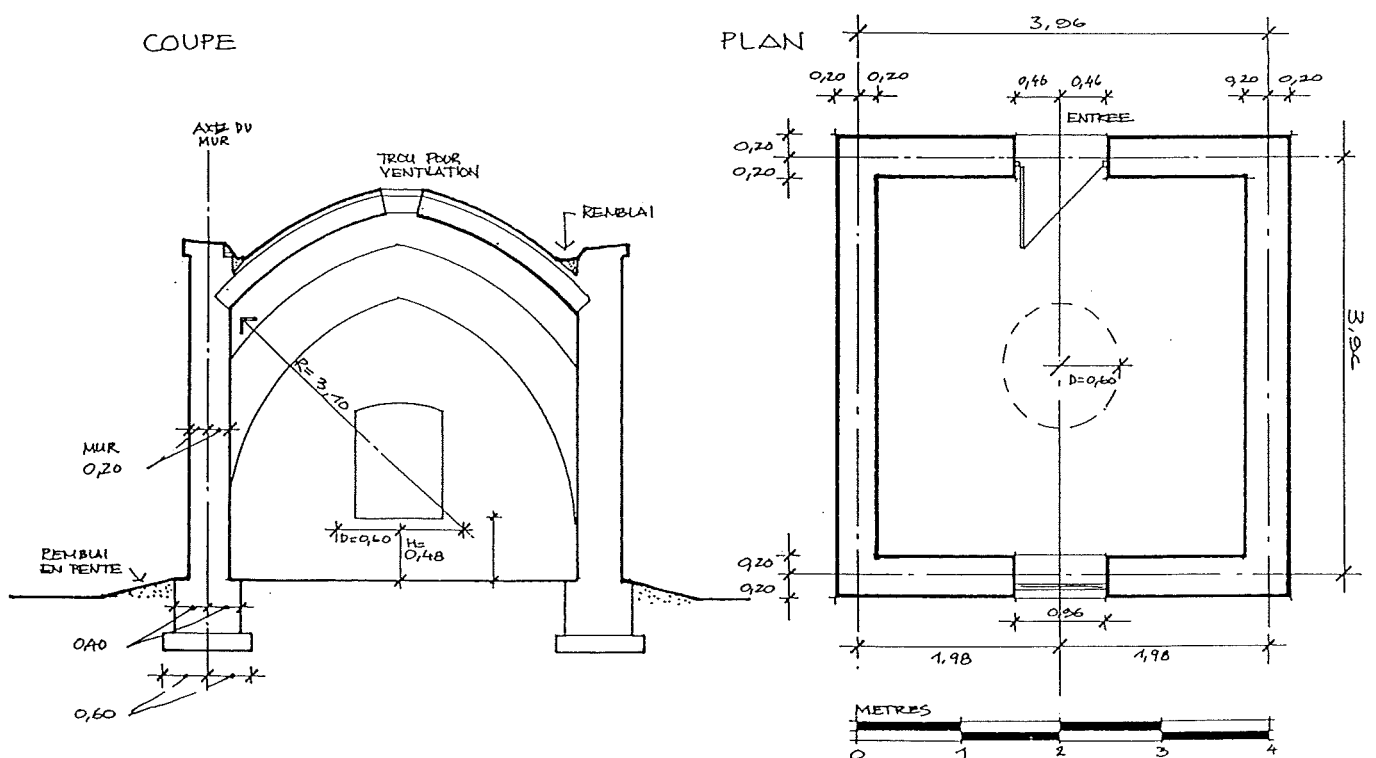

Appendix 5, contd.

Dome on round base - plan and section

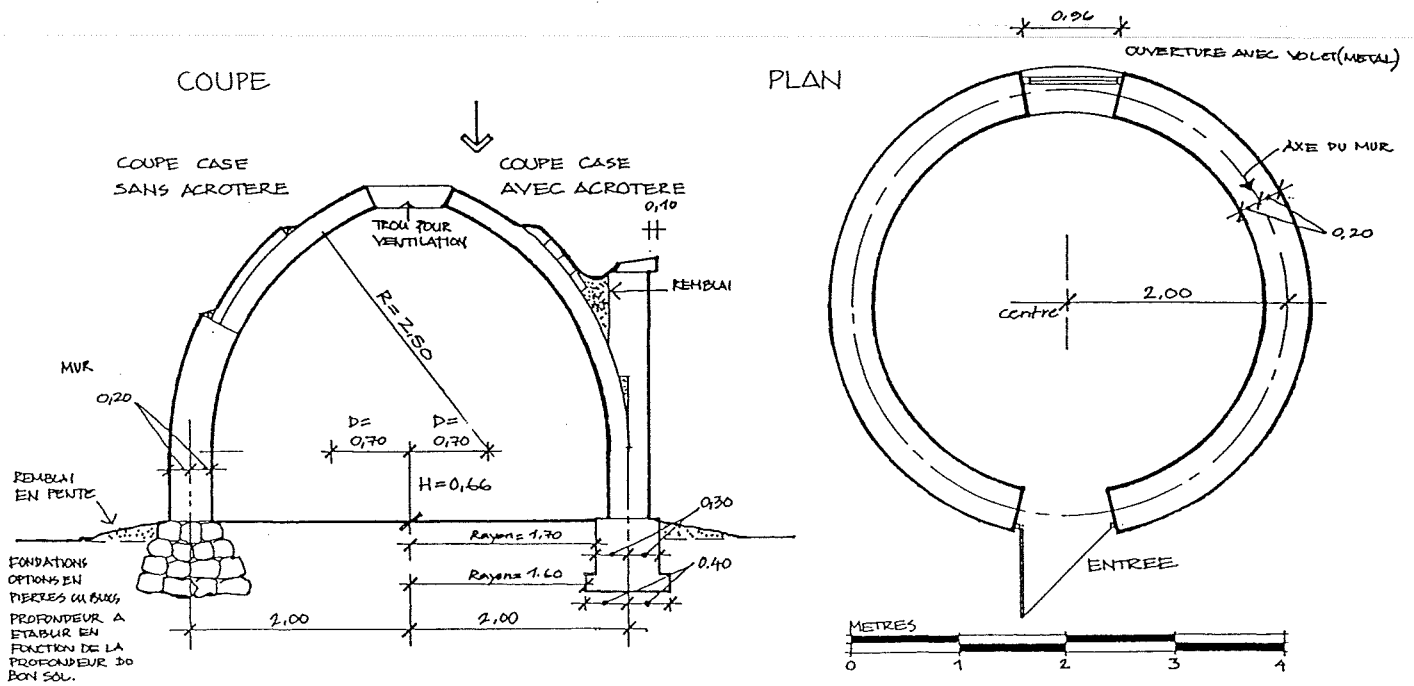

Vault on rectangular base - plan and section

